

Section 02

Air treatment

Components for compressed air treatment

Air service units

Wide range of components for compressed air treatment, are available in aluminium, technopolymer and steel, in several sizes with connections from 1/8" to 1" and flow rates up to 8000 NI/m.

| | | | | |
|--|--|--|---|-------|
| | Series AIRPLUS | 2.1 | | |
| | Product overview | 2.3 | Regulators | 2.33 |
| | Filter | 2.5 | Piloted pressure regulators | 2.39 |
| | Coalescing filter | 2.10 | Pressure regulators for manifold | 2.44 |
| | Oil removal filters | 2.15 | Manifold pressure regulators | 2.48 |
| | Carbon filters | 2.20 | Lubricators | 2.53 |
| | Filter regulators | 2.25 | Shut off valves | 2.58 |
| | Accessories | 2.32 | Progressive start-up valve | 2.62 |
| | | | Air intake | 2.65 |
| | | | Pressure switch | 2.67 |
| | | | Air intake with pressure gauge or digital pressure switch integrated | 2.69 |
| | | | Safeline valves | 2.75 |
| | | | Manifold unit | 2.82 |
| | Series 1700 | 2.88 | | |
| | Product overview | 2.88 | Piloted pressure regulators | 2.115 |
| | Filter | 2.90 | High sensitive pressure regulator with pneumatic pilot | 2.119 |
| | Coalescing filter | 2.94 | Panel mounting pressure regulator | 2.121 |
| | Dynamic drier | 2.98 | Panel mounting pressure regulator including pressure gauge | 2.123 |
| | Filter regulators | 2.100 | Pressure regulators for manifold | 2.125 |
| | Regulators | 2.104 | Manifold pressure regulators | 2.127 |
| | Regulators with integrated pressure gauge | 2.109 | Lubricators | 2.130 |
| | High sensitive air pressure regulators with high flow rate relieving | 2.112 | Shut-off valve | 2.134 |
| | | | Electric shut-off valve | 2.136 |
| | | | Pneumatic shut-off valve | 2.138 |
| | | | Progressive start-up valve | 1.140 |
| | | | Presa d'aria | 2.142 |
| | | Air Intake - "H" profile | 2.144 | |
| | | Pressure Switch complete with adapter | 2.146 | |
| | | Manifold unit | 2.148 | |
| | | Accessories | 2.156 | |
| | Series 1700 Steel line | 2.159 | | |
| | Sizes 2 | 2.160 | Sizes 3 | 2.165 |
| | | | Sizes 4 | 2.168 |
| | | | | |

Proportional technology

The proportional pressure regulators are available in 3 sizes, standard, CANopen® and IO-Link, or miniaturized versions

| | | | | | |
|--|-----------------------------|--------------|--|---------------------------------|--------------|
| | Series 1700 standard | 2.172 | | Series 1700 Miniaturized | 2.188 |
| | | | | | |

Measuring devices

Digital pressure switches and pressure gauges, panel mounting or manifold versions

| | | | | | |
|--|------------------------------------|--------------|--|----------------------------------|--------------|
| | Pressure switches Series DS | 2.204 | | Pressure gauges Series DS | 2.206 |
| | | | | | |

Pressure booster

3 sizes aluminium Pressure boosters available or technopolymer with 2:1 compression ratio

| | | | | | |
|--|--------------------|--------------|--|------------------|--------------|
| | Series 1700 | 2.208 | | Series P+ | 2.213 |
| | | | | | |



Product overview

| PRODUCT | VERSION | SIZE | | | | MAX. PRESSURE | | MIN - MAX AMBIENT TEMPERATURE | | ATEX |
|---|--|--------|--------|--------|--------|--|---|-------------------------------|---|------|
| | | Size 1 | Size 2 | Size 3 | Size 4 | Technopolymer body or bowl | Metal body and bowl | Technopolymer body or bowl | Metal body and bowl | |
| FILTER (F) | T : Technopolymer body and thread | • | • | • | | 13 bar - 10 bar (automatic drain) | / 20 bar - 16 bar (automatic drain) | -5°C +50°C | / -30°C +80°C -40°C +80°C | • |
| | N : Technopolymer body and metal inserts | • | • | • | | | | | | |
| | P : Aluminum body | | • | • | • | | | | | |
| | L : Aluminum body, low temperature | | • | • | • | | | | | |
| COALESCING FILTER (D) | T : Technopolymer body and thread | • | • | • | | 13 bar - 10 bar (automatic drain) | / 20 bar - 16 bar (automatic drain) | -5°C +50°C | / -30°C +80°C -40°C +80°C | • |
| | N : Technopolymer body and metal inserts | • | • | • | | | | | | |
| | P : Aluminum body | | • | • | • | | | | | |
| | L : Aluminum body, low temperature | | • | • | • | | | | | |
| OIL REMOVAL FILTER (DBV) (DCV) (DAV) | T : Technopolymer body and thread | | | • | | 10 bar | / | -5°C +50°C | / | • |
| | N : Technopolymer body and metal inserts | | | • | | | | | | |
| | P : Aluminum body | | | • | • | | | | | |
| | L : Aluminum body, low temperature | | | | | | | | | |
| CARBON FILTER (DD) | T : Technopolymer body and thread | | | • | | 13 bar | / 20 bar | -5°C +50°C | / -30°C +80°C -40°C +80°C | • |
| | N : Technopolymer body and metal inserts | | | • | | | | | | |
| | P : Aluminum body | | | • | • | | | | | |
| | L : Aluminum body, low temperature | | | • | • | | | | | |
| REGULATOR (R) (RM) (RW) | T : Technopolymer body and thread | • | • | • | | 13 bar | 20 bar | -5°C +50°C | / -30°C +80°C -40°C +80°C | • |
| | N : Technopolymer body and metal inserts | • | • | • | | | | | | |
| | P : Aluminum body | | • | • | • | | | | | |
| | L : Aluminum body, low temperature | | • | • | • | | | | | |
| PRESSURE REGULATOR FOR MANIFOLD (B) (M) | T : Technopolymer body and thread | • | | | | 13 bar | / | -5°C +50°C | / / | • |
| | N : Technopolymer body and metal inserts | • | | | | | | | | |
| | P : Aluminum body | | | | | | | | | |
| | L : Aluminum body, low temperature | | | | | | | | | |
| PILOTED PRESSURE REGULATOR (RP) (RMP) (RPP) | T : Technopolymer body and thread | | | | | / | / | / | / | • |
| | N : Technopolymer body and metal inserts | | | | | / | 20 bar | / | -30°C +80°C | |
| | P : Aluminum body | | | | • | / | | / | / | |
| | L : Aluminum body, low temperature | | | | | / | | / | / | |
| PILOTED PRESSURE REGULATOR WITH DIGITAL PRESSURE SWITCH (RPP) (RPZ) | T : Technopolymer body and thread | | | | | / | / | / | / | • |
| | N : Technopolymer body and metal inserts | | | | | / | 20 bar | / | 0°C +50°C | |
| | P : Aluminum body | | | | • | / | | / | / | |
| | L : Aluminum body, low temperature | | | | | / | | / | / | |
| FILTER REGULATOR (E) (EM) (EW) | T : Technopolymer body and thread | • | • | • | | 13 bar - 10 bar (automatic drain) | 20 bar - 16 bar (automatic drain) | -5°C +50°C | / -30°C +80°C -40°C +80°C | • |
| | N : Technopolymer body and metal inserts | • | • | • | | | | | | |
| | P : Aluminum body | | • | • | • | | | | | |
| | L : Aluminum body, low temperature | | • | • | • | | | | | |
| REGULATOR WITH DIGITAL PRESSURE SWITCH (RP) (RZ) | T : Technopolymer body and thread | • | • | • | | 13 bar | 20 bar | 0°C +50°C | | • |
| | N : Technopolymer body and metal inserts | • | • | • | | | | | | |
| | P : Aluminum body | | • | • | • | | | | | |
| | L : Aluminum body, low temperature | | • | • | • | | | | | |
| FILTER REGULATOR WITH DIGITAL PRESSURE SWITCH (E) (EP) (EZ) | T : Technopolymer body and thread | • | • | • | | 13 bar - 10 bar (automatic drain) | 20 bar - 16 bar (automatic drain) | 0°C +50°C | | • |
| | N : Technopolymer body and metal inserts | • | • | • | | | | | | |
| | P : Aluminum body | | • | • | • | | | | | |
| | L : Aluminum body, low temperature | | • | • | • | | | | | |
| LUBRICATOR (L) | T : Technopolymer body and thread | • | • | • | | 13 bar | / | -5°C +50°C | / | • |
| | N : Technopolymer body and metal inserts | • | • | • | | | | | | |
| | P : Aluminum body | | • | • | • | | | | | |
| | L : Aluminum body, low temperature | | | | | | | | | |

2 AIR TREATMENT



2
AIR TREATMENT

| PRODUCT | VERSION | SIZE | | | | MAX. PRESSURE | | MIN - MAX AMBIENT TEMPERATURE | | ATEX |
|--|---|--------|--------|--------|--------|---------------------------------------|---------------------|-------------------------------|---------------------|------|
| | | Size 1 | Size 2 | Size 3 | Size 4 | Technopolymer body or bowl | Metal body and bowl | Technopolymer body or bowl | Metal body and bowl | |
| LUBRICATOR WITH ELECTRICAL MINIMUM LEVEL SENSOR (LA) (LC) | T: Technopolymer body and thread | ● | ● | ● | | 13 bar | | -5°C +50°C | | |
| | N: Technopolymer body and metal inserts | ● | ● | ● | | | | | | |
| | P: Aluminum body | | ● | ● | ● | | | | | |
| | L: Aluminum body, low temperature | | | | | | | | | |
| SHUT OFF VALVE (VL) | T: Technopolymer body and thread | ● | ● | ● | | 13 bar - 10 bar (for size 4) | | -5°C +50°C | / | ● |
| | N: Technopolymer body and metal inserts | ● | ● | ● | | | | | | |
| | P: Aluminum body | | ● | ● | ● | | | | | |
| | L: Aluminum body, low temperature | | ● | ● | ● | | | | | |
| PNEUMATIC SHUT OFF VALVE (VP) | T: Technopolymer body and thread | ● | ● | ● | | 13 bar | 20 bar | -5°C +50°C | / | ● |
| | N: Technopolymer body and metal inserts | ● | ● | ● | | | | | | |
| | P: Aluminum body | | ● | ● | ● | | | | | |
| | L: Aluminum body, low temperature | | ● | ● | ● | | | | | |
| ELECTRIC SHUT OFF VALVE (VE) | T: Technopolymer body and thread | ● | ● | ● | | 10 bar | | -5°C +50°C | | ● |
| | N: Technopolymer body and metal inserts | ● | ● | ● | | | | | | |
| | P: Aluminum body | | ● | ● | ● | | | | | |
| | L: Aluminum body, low temperature | | | | | | | | | |
| PROGRESSIVE START-UP VALVE (AP) | T: Technopolymer body and thread | ● | ● | ● | | 13 bar - 10 bar (for size 4) | | -5°C +50°C | | ● |
| | N: Technopolymer body and metal inserts | ● | ● | ● | | | | | | |
| | P: Aluminum body | | ● | ● | ● | | | | | |
| | L: Aluminum body, low temperature | | ● | ● | ● | | | | | |
| AIR INTAKE (PA) | T: Technopolymer body and thread | ● | ● | ● | | 13 bar | 20 bar | -5°C +50°C | / | ● |
| | N: Technopolymer body and metal inserts | ● | ● | ● | | | | | | |
| | P: Aluminum body | | ● | ● | ● | | | | | |
| | L: Aluminum body, low temperature | | | | | | | | | |
| PRESSURE SWITCH (PP) | T: Technopolymer body and thread | ● | ● | ● | | 13 bar | 20 bar | -5°C +50°C | | |
| | N: Technopolymer body and metal inserts | ● | ● | ● | | | | | | |
| | P: Aluminum body | | ● | ● | ● | | | | | |
| | L: Aluminum body, low temperature | | | | | | | | | |
| AIR INTAKE WITH INTEGRATED PRESSURE GAUGE (PM-PW) | T: Technopolymer body and thread | ● | ● | ● | | 13 bar | | -5°C +50°C | / | ● |
| | N: Technopolymer body and metal inserts | ● | ● | ● | | | | | | |
| | P: Aluminum body | | ● | ● | ● | | | | | |
| | L: Aluminum body, low temperature | | | | | | | | | |
| AIR INTAKE WITH INTEGRATED DIGITAL PRESSURE SWITCH (PP-PZ) | T: Technopolymer body and thread | ● | ● | ● | | 13 bar | | 0°C +50°C | | |
| | N: Technopolymer body and metal inserts | ● | ● | ● | | | | | | |
| | P: Aluminum body | | ● | ● | ● | | | | | |
| | L: Aluminum body, low temperature | | | | | | | | | |

Air service units, series AIRPLUS

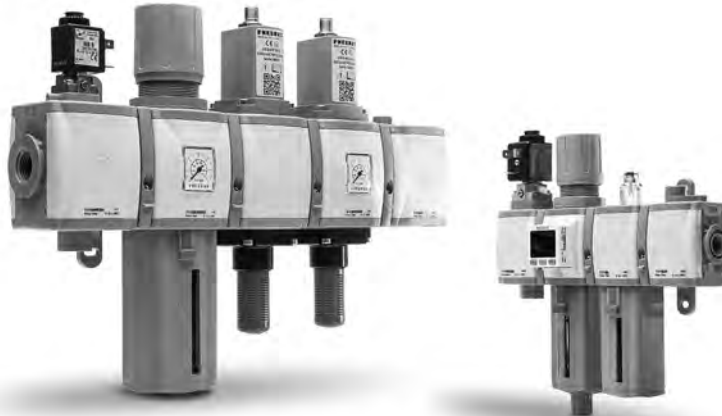

- **Modular system**
- **Compact and linear design**
- **Maximum flexibility and reliability**
- **Plug-n-play connection thru couplig flanges**
- **Integral safety elements in assembled group**
- **Available in 4 sizes with connections from 1/8" to 1"**
- **ATEX certification (II 2GD or II 3GD)**

Construction and working characteristics

Pneumax AIRPLUS air treatment units have been designed and developed to increase reliability, modularity and user-friendly operation and installation.

Thanks to a wide range of modules with different functions and characteristics, together with a wide choice of materials selection, make the Pneumax AIRPLUS air treatment units a robust, reliable and extremely flexible modular system, adaptable to many applications.

AIRPLUS units correctly assembled are modular with unlimited configurations and solutions, capable of fulfilling all functions of compressed air treatment such as filtration, regulation, lubrication, interception and distribution.

Filters, including coalescing and active carbon elements as well as oil separators provide adequate media filtration. Precise and reliable pressure regulation is provided by the regulators or filter-regulators which are also available with a built in pressure gauge or integral digital pressure switch. The lubricators provide oil mist lubrication in proportion to air being consumed whilst the shut-off valves, which can be operated pneumatic, electro-pneumatic or manually will effectively manage the supply and exhaust of the compressed air system.

The range is completed by a series of complementary modules, such as pneumatic connection by-pass, pressure switch and progressive start-up. The complete assembly is built up using the individual modules connected together via quick coupling flanges which provide a 'plug & play' assembly. This provides quick and easy installation or replacement.

Pneumax Airplus air treatment units can be integrated with safety elements that comply with EN-ISO 13849-1 and CE marking according to EU Machinery Directive, Annex V.

AIRPLUS air treatment units are available in 4 different sizes, with connections from 1/8" to 1" and flow rates performances up to 8000NI/min.

Instruction for installation and operation

The FRL unit should be installed as close as possible to the 'point of use'. The air flow direction should follow the direction indicated on the individual modules, following threaded connections (IN and OUT). Units fitted with a with bowl should be mounted vertically with the bowl facing down.

All units should be operated in accordance to the specified pressure and temperature ranges and should never exceed 0.2 Hz max frequency whether pulsing inlet pressure occur.

Fittings shall be mounted according to the maximum torque specified.

Maintenance

To carry out maintenance which involves the removal of the caps or supports above the body and where the retaining screws are present, it is necessary to remove the cover plates beforehand. If you attempt to dis-assemble the caps or supports without removing the cover plates and retaining screws, the integrity and function of the device could be compromised.

Bowls, plugs and supports are assembled with a bayonet type mechanism. In order to remove them, rotate anti-clockwise until the mechanical stop is reached and then remove from the body (for the bowls firstly press down the green safety button).

Bowls and transparent parts can be cleaned with water and neutral soap. Do not use solvents or alcohol.

Filtering elements (present in filters and filter regulators) made of HDPE can be regenerated by washing and blowing them.

In order to remove them it is necessary to remove the bowl unscrew the filter element and replace it with a new one or clean it.

Lubricator oil recharge might be performed during normal operation (apart TG1 size) depressurizing the bowl thru dedicated plug.

Pneumax suggest refilling oil directly into the bowl.

No others maintenance operation shall be carried out by client itself, due to complexity of the assembly and Pneumax dedicated post-maintenance testing activities.



FILTRATION



Filter pore sizes
from 50 μm to 5 μm

Coalescing filter with
retention efficiency of 99,97%
particle removal down to 0,01 μm

Coalescing/oil removal filter
with oil residual up to 0,01 ppm

Carbon filter
with oil residual up to < 0,003 ppm

REGULATION



Regulators and filter regulators

Pressure regulation range up to 12 bar

Available with
integrated pressure gauge,
pressure switch or G1/8" connection

LUBRICATION



Manual adjustment of oil quantity
complete with visual indicator

Oil refilled with
pressurized circuit

Oil mist lubrication

SHUT OFF



Manual, pneumatic
or electropneumatic
operation availability

Manual version lockable
up to 3 padlock

COMPLEMENTARY MODULES

Pressure switch

Air intake

Progressive start-up valve



SAFETY

Integrated diagnostic system

Single version CAT.2
in accordance with
ISO EN 13849 up to PL=C

Double version CAT.4
in accordance with
ISO EN 13849 up to PL=E

In accordance with
EU Machinery directive,
annex V



Filters (F)



- ▶ Double filter action: air flow centrifugation and filter element
- ▶ Available in 4 sizes with flow rates up to 14000 NI/min and connections from 1/8" to 1"
- ▶ Filtering cartridge made of HDPE available in three different filtration grades (5µm, 20µm, 50µm)
- ▶ Filter cartridge can be regenerated by washing / blowing it or replaced
- ▶ Bowl assembly via bayonet type quick coupling mechanism with safety button
- ▶ Semi-automatic or automatic drain
- ▶ Atex certification (II 2GD or II 3GD)
- ▶ Inlet pressures up to 20 bar

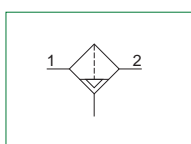
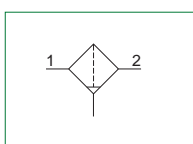

Note
In order to ensure that any fluid discharged by the auto drain assembly is adequately drained away, it is recommended you use a 6mm fitting and tube.

| Technical characteristics | | Size | Size 1 | Size 2 | Size 3 | Size 4 | |
|--|------------------------|---|--------|---|--------|--|---|
| Body and connections type | | Technopolymer body, integrated technopolymer connections (T version) Technopolymer body, metal connections (N version) | | | | / | / |
| Protection and bowl type | | Technopolymer protection - PC bowl Technopolymer protection - PA bowl | | Aluminium body, integrated aluminium connections (P - L versions) | | | |
| IN / OUT connections | T version | G1/4" | | G3/8" | | G1/2" | |
| | N version | G1/8" - G1/4" - 1/4" NPT | | G3/8" - G1/4" - 3/8" NPT | | G3/8" - G1/2" - 1/2" NPT | |
| | P and L version | not available | | G3/8" - 1/4" NPT | | G1/2" - 1/2" NPT | |
| Assembly configuration | | Stand alone | | | | Panel mounted | |
| Assembly positions | | Vertical ±5° | | | | | |
| Filter pore size | | 5 µm 20 µm 50 µm | | | | | |
| Bowl capacity | | 18 cm ³ | | 34 cm ³ | | 90 cm ³ | |
| Condensation drain | | Semi-automatic Automatic | | | | | |
| Max. fittings torque IN / OUT connections | | G1/8" metal: 15Nm G1/4" metal: 20Nm G1/4" technopolymer: 9Nm | | G1/4" metal: 20Nm G3/8" metal: 25Nm G3/8" technopolymer: 16Nm | | G3/8" metal: 25Nm G1/2" metal: 30Nm G1/2" technopolymer: 22Nm G1" metal: 35Nm | |

| Operational characteristics | | | | | | | | |
|---------------------------------|------------|----------------|--|--------|------------|--------|--|--------|
| Size | Size 1 | Size 2 | Size 3 | Size 4 | Size 1 | Size 2 | Size 3 | Size 4 |
| Condensation drain | | Semi-automatic | | | Automatic | | | |
| Maximum working pressure | 13 bar | | 20 bar (only with body and metal bowl) | | 10 bar | | 16 bar (only with body and metal bowl) | |
| Minimum working pressure | 0,5 bar | | | | 0,5 bar | | | |
| Working temperature | -5°C +50°C | | -30°C +80°C (only for P version and metal bowl) -40°C +80°C (only for L version and metal bowl) | | -5°C +50°C | | | |

2
AIR TREATMENT

| Weights | | | | | |
|--|------|--------|--------|--------|--------|
| | Size | Size 1 | Size 2 | Size 3 | Size 4 |
| Fully technopolymer version | | 129 g | 226 g | 355 g | / |
| Technopolymer body version, aluminium bowl protection and technopolymer bowl | | / | 257 g | 393 g | / |
| Technopolymer body version, aluminium bowl | | / | 301 g | 465 g | / |
| Aluminium body version, technopolymer protection and bowl | | / | 314 g | 477 g | 1163 g |
| Aluminium body version, aluminium bowl protection and technopolymer bowl | | / | 344 g | 514 g | 1306 g |
| Aluminium body version and aluminium bowl | | / | 389 g | 587 g | 1330 g |

Materials

Exploded sectioned

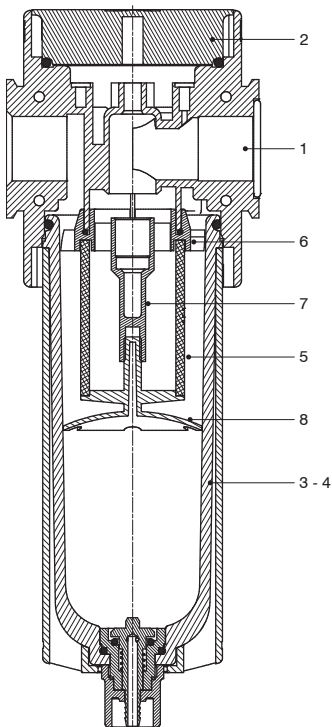

| Filter | | |
|--------|-------------------------------|--|
| 1 | Body | Polyamide Die-cast aluminium |
| 2 | Plug | Polyamide |
| 3 | Technopolymer bowl | Polycarbonate Polyamide |
| 4 | Metal bowl Bowl protection | Die-cast aluminium Polyamide - Die-cast aluminium |
| 5 | Filtering element | Polyethylene |
| 6 | Baffle | Acetal resin |
| 7 | Spool support | Acetal resin |
| 8 | Filtering element support | Acetal resin |

2
AIR TREATMENT

Design

Size 1 - Size 2 - Size 3
Technopolymer protection

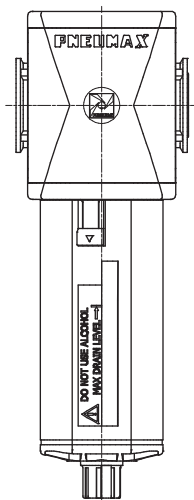

Size 1 - Size 2 - Size 3
Protection / Metal bowl

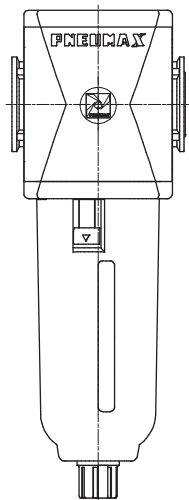

Size 4
All versions

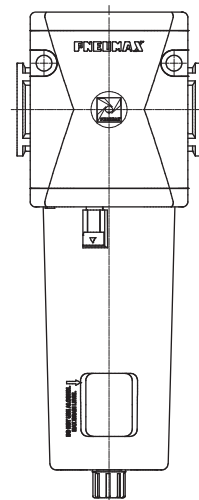



Order codes

| | | | | | | | |
|---|----------|-----------|-----------|----------|----------|----------|----------|
| | T | 17 | 3B | F | B | S | T |
| Version | | | | | | | |
| N : Technopolymer body and metal inserts (not available for size 4) | | | | | | | |
| T : Technopolymer body and thread (not available for size 4) | | | | | | | |
| P : Aluminum body (not available for size 1) | | | | | | | |
| L : Aluminum body, low temperature (not available for size 1) | | | | | | | |
| Size and connections | | | | | | | |
| 1A : Size 1 - G1/8" only for N version | | | | | | | |
| 1B : Size 1 - G1/4" only for T - N versions | | | | | | | |
| 1C : Size 1 - 1/4" NPT only for N version | | | | | | | |
| 2A : Size 2 - G1/4" only for N version | | | | | | | |
| 2B : Size 2 - G3/8" for all versions | | | | | | | |
| 2C : Size 2 - 3/8" NPT only for N version - 1/4" NPT only for P - L versions | | | | | | | |
| 3A : Size 3 - G3/8" only for N version | | | | | | | |
| 3B : Size 3 - G1/2" for all versions | | | | | | | |
| 3C : Size 3 - 1/2" NPT only for N - P - L versions | | | | | | | |
| 4B : Size 4 - G1" only for P - L versions | | | | | | | |
| 4C : Size 4 - 1" NPT only for P - L versions | | | | | | | |
| Filter pore size | | | | | | | |
| A : 5 μm | | | | | | | |
| B : 20 μm | | | | | | | |
| C : 50 μm | | | | | | | |
| Condensation drain | | | | | | | |
| : Semi-automatic drain | | | | | | | |
| S : Automatic drain | | | | | | | |
| Bowl options | | | | | | | |
| : Technopolymer protection - PC bowl | | | | | | | |
| N : Technopolymer protection - PA bowl | | | | | | | |
| P : Metal protection - PC bowl (not available for size 1) | | | | | | | |
| R : Metal protection - PA bowl (not available for size 1) | | | | | | | |
| T : Metal bowl (not available for size 1) | | | | | | | |

Example : T173BFBST : Size 3 filter G1/2" 20 μm, automatic drain and metal bowl

Characteristic curves

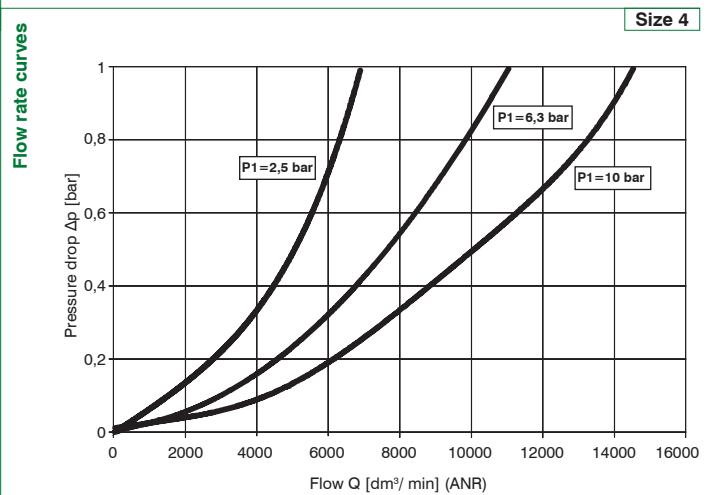
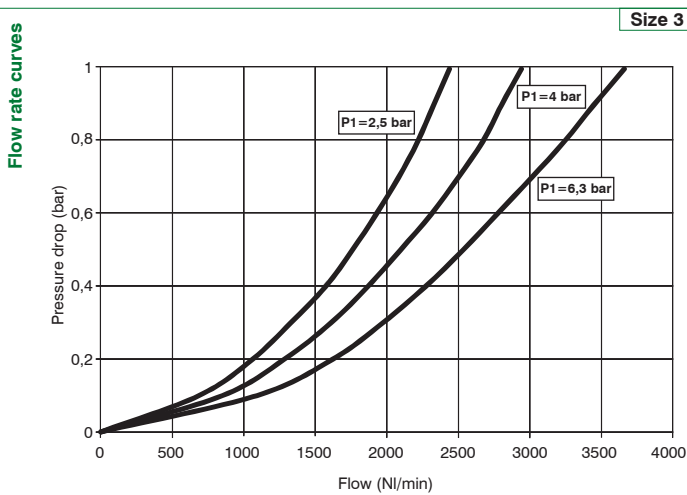
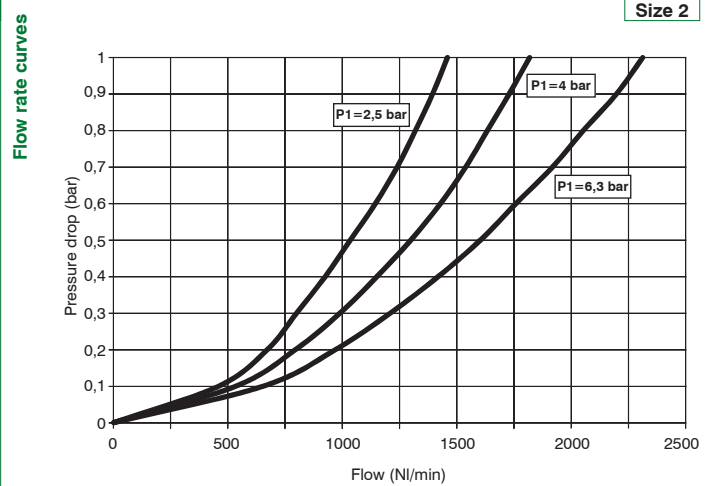
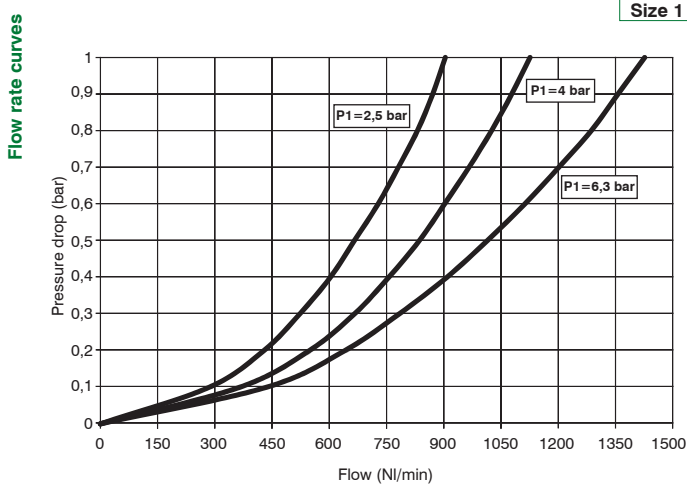

Dimensions

Semi-automatic drain version

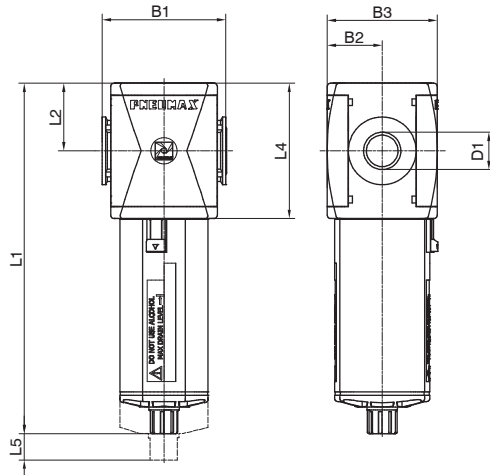

Fixing holes dimension detail (only for size 4)

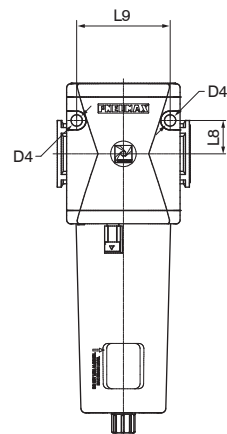

| Model | B1 | B2 | B3 | D1 | D4 | L1 - Bowl material | | L2 | L4 | L5 | L8 | L9 |
|--------|----|------|----|--|-----|--------------------|-------|------|-----|-----|----|----|
| | | | | | | Technopolymer | Metal | | | | | |
| #171.. | 48 | 21 | 42 | G1/8" G1/4" 1/4" NPT | / | 148 | / | 27,5 | 55 | 40 | / | / |
| #172.. | 62 | 28,5 | 57 | G1/4" G3/8" 1/4" NPT 3/8" NPT | / | 169,1 | 171,5 | 34 | 68 | 50 | / | / |
| #173.. | 73 | 32,5 | 65 | G3/8" G1/2" 1/2" NPT | / | 207,2 | 209,5 | 40 | 80 | 65 | / | / |
| #174.. | 99 | 44 | 88 | G1" 1" NPT | 8,5 | 262 | 264,5 | 52,5 | 105 | 103 | 25 | 70 |

Variable dimensions

Semi-automatic drain version

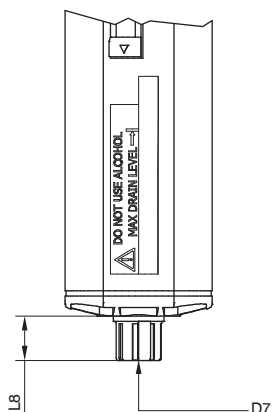

Automatic drain version

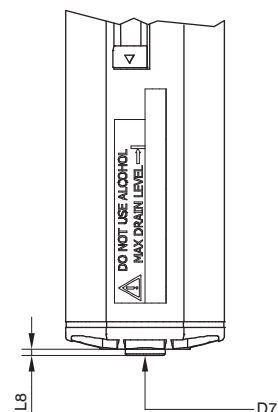

| Model | L8 - Bowl material | | D7 |
|----------------------|--------------------|-------|------------------------|
| | Technopolymer | Metal | |
| Semi-automatic drain | 15,7 | 18 | Plastic hose connector |
| Automatic drain | 2 | 4,5 | G1/8" |

► **Coalescing filters (DA)**



- Coalescing filter
- Available in 4 sizes with flow rates up to 8000 NI/min and connections from 1/8" to 1"
- Filtering cartridge with filtration grade of 0,01 μm
- Filtering performances 99.97% (particles up to 0.01 μm)
- Bowl assembly via bayonet type quick coupling mechanism with safety button
- Semi-automatic or automatic drain
- Atex certification (II 2GD or II 3GD)
- Inlet pressures up to 20 bar

2

AIR TREATMENT

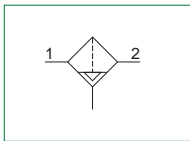
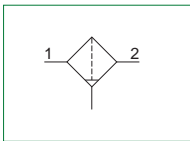

Note

In order to ensure the high level of filtration, it is recommended that a 5μ filter is installed before the coalescing filter. In order to ensure that any fluid discharged by the auto drain assembly is adequately drained away, it is recommended you use a 6mm fitting and tube.

| Technical characteristics | | | | | |
|--|------------------------|---|---|---|--------------------|
| Size | | Size 1 | Size 2 | Size 3 | Size 4 |
| Body and connections type | | Technopolymer body, integrated technopolymer connections (T version) Technopolymer body, metal connections (N version) | | | / |
| | | / | Aluminium body, integrated aluminium connections (P - L versions) | | / |
| Protection and bowl type | | Technopolymer protection - PC bowl Technopolymer protection - PA bowl | | Metal protection - PC bowl Metal protection - PA bowl Metal bowl (blind metal bowl) | |
| IN / OUT connections | T version | G1/4" | G3/8" | G1/2" | not available |
| | N version | G1/8" - G1/4" - 1/4" NPT | G3/8" - G1/4" - 3/8" NPT | G3/8" - G1/2" - 1/2" NPT | |
| | P and L version | not available | G3/8" | G1/2" | G1" |
| Assembly configuration | | Stand alone | | | Panel mounted |
| Assembly positions | | Vertical ±5° | | | |
| Filter pore size | | 0,01 μm, efficiency of 99,97% | | | |
| Bowl capacity | | 18 cm ³ | 34 cm ³ | 68 cm ³ | 90 cm ³ |
| Condensation drain | | Semi-automatic Automatic | | | |
| Max. fittings torque IN / OUT connections | | G1/8" metal: 15Nm G1/4" metal: 20Nm G1/4" technopolymer: 9Nm | G1/4" metal: 20Nm G3/8" metal: 25Nm G3/8" technopolymer: 16Nm | G3/8" metal: 25Nm G1/2" metal: 30Nm G1/2" technopolymer: 22Nm | G1" metal: 35Nm |

| Operational characteristics | | | | | | | | |
|---------------------------------|----------------|--|--|--------|------------|--|--------|--------|
| Size | Size 1 | Size 2 | Size 3 | Size 4 | Size 1 | Size 2 | Size 3 | Size 4 |
| Condensation drain | Semi-automatic | | | | Automatic | | | |
| Maximum working pressure | 13 bar | 20 bar (only with body and metal bowl) | | | 10 bar | 16 bar (only with body and metal bowl) | | |
| Minimum working pressure | 0,5 bar | | | | 0,5 bar | | | |
| Working temperature | -5°C +50°C | | -30°C +80°C (only for P version and metal bowl) -40°C +80°C (only for L version and metal bowl) | | -5°C +50°C | | | |

| Weights | | | | | |
|--|------|--------|--------|--------|--------|
| | Size | Size 1 | Size 2 | Size 3 | Size 4 |
| Fully technopolymer version | | 130 g | 224 g | 366 g | / |
| Technopolymer body version, aluminium bowl protection and technopolymer bowl | | / | 251 g | 402 g | / |
| Technopolymer body version, aluminium bowl | | / | 293 g | 475 g | / |
| Aluminium body version, technopolymer protection and bowl | | / | 309 g | 493 g | 1197 g |
| Aluminium body version, aluminium bowl protection and technopolymer bowl | | / | 337 g | 529 g | 1340 g |
| Aluminium body version and aluminium bowl | | / | 378 g | 603 g | 1365 g |

Materials

Exploded sectioned

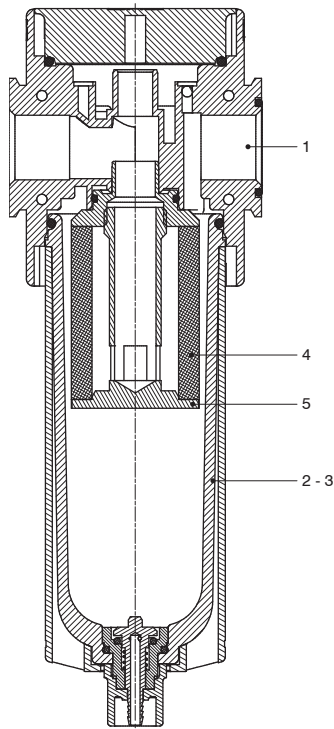

| Coalescing filter | | |
|-------------------|-------------------------------|--|
| 1 | Body | Polyamide Die-cast aluminium |
| 2 | Technopolymer bowl | Polycarbonate Polyamide |
| 3 | Metal bowl Bowl protection | Die-cast aluminium Polyamide - Die-cast aluminium |
| 4 | Filtering element | Borosilicate glass fiber |
| 5 | Filtering element support | Aluminium |

2

AIR TREATMENT

Design

Size 1 - Size 2 - Size 3
Technopolymer protection

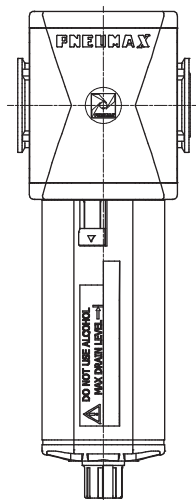

Size 1 - Size 2 - Size 3
Protection / Metal bowl

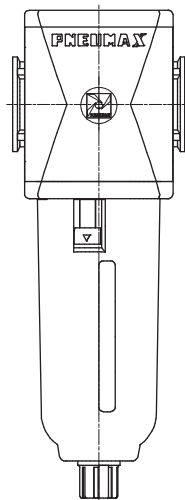

Size 4
All versions

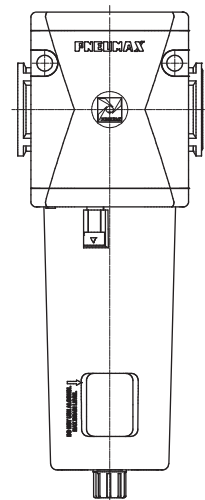



Order codes

T 17 3B DA S T

| Version |
|---|
| N : Technopolymer body and metal inserts (not available for size 4) |
| T : Technopolymer body and thread (not available for size 4) |
| P : Aluminum body (not available for size 1) |
| L : Aluminum body, low temperature (not available for size 1) |

| Size and connections |
|---|
| 1A : Size 1 - G1/8" only for N version |
| 1B : Size 1 - G1/4" only for T - N versions |
| 1C : Size 1 - 1/4" NPT only for N version |
| 2A : Size 2 - G1/4" only for N version |
| 2B : Size 2 - G3/8" for all versions |
| 2C : Size 2 - 3/8" NPT only for N version |
| 3A : Size 3 - G3/8" only for N version |
| 3B : Size 3 - G1/2" for all versions |
| 3C : Size 3 - 1/2" NPT only for N version |
| 4B : Size 4 - G1" only for P - L versions |

| Condensation drain |
|------------------------|
| : Semi-automatic drain |
| S : Automatic drain |

| Bowl options |
|---|
| : Technopolymer protection - PC bowl |
| N : Technopolymer protection - PA bowl |
| P : Metal protection - PC bowl (not available for size 1) |
| R : Metal protection - PA bowl (not available for size 1) |
| T : Metal bowl (not available for size 1) |

Example : T173BDAST : Size 3 coalescing filter G1/2" 0,01 µm, automatic drain and metal bowl

2
AIR TREATMENT

Characteristic curves

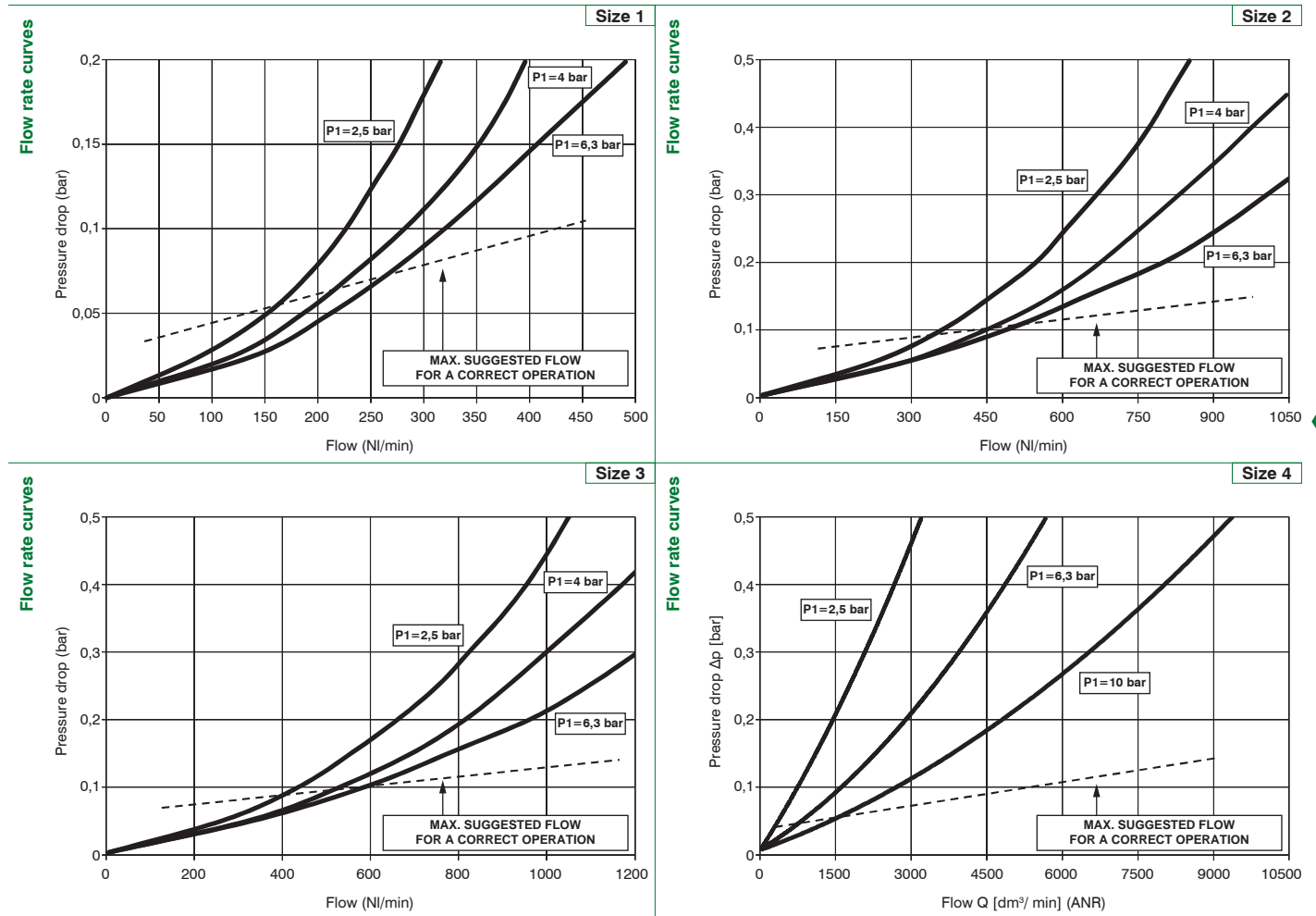

2

AIR TREATMENT

Dimensions

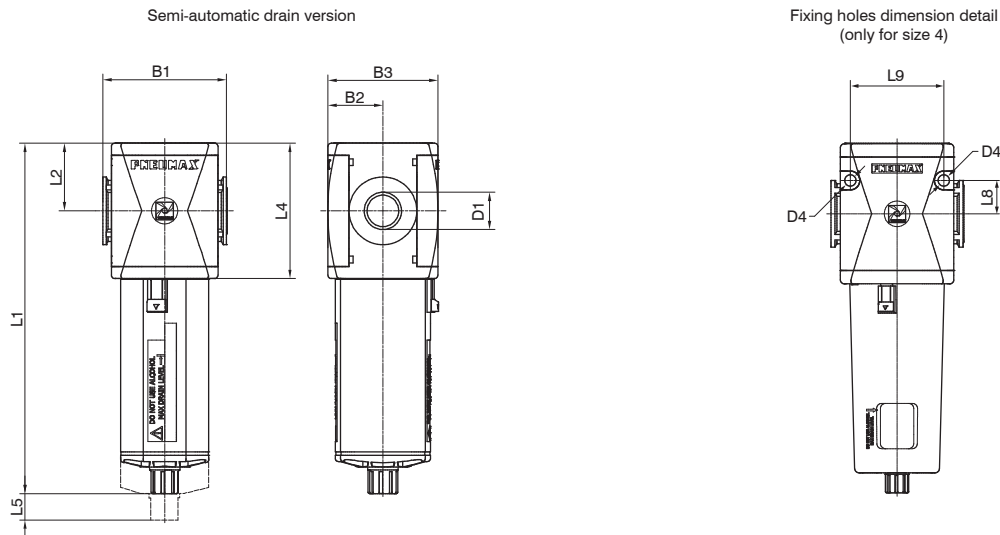

| Model | B1 | B2 | B3 | D1 | D4 | L1 - Bowl material | | L2 | L4 | L5 | L8 | L9 |
|--------|----|------|----|--|-----|--------------------|-------|------|-----|-----|----|----|
| | | | | | | Technopolymer | Metal | | | | | |
| #171.. | 48 | 21 | 42 | G1/8" G1/4" 1/4" NPT | / | 148 | / | 27,5 | 55 | 40 | / | / |
| #172.. | 62 | 28,5 | 57 | G1/4" G3/8" 1/4" NPT 3/8" NPT | / | 169,1 | 171,5 | 34 | 68 | 50 | / | / |
| #173.. | 73 | 32,5 | 65 | G3/8" G1/2" 1/2" NPT | / | 207,2 | 209,5 | 40 | 80 | 65 | / | / |
| #174.. | 99 | 44 | 88 | G1" 1" NPT | 8,5 | 262 | 264,5 | 52,5 | 105 | 103 | 25 | 70 |

Variable dimensions

Semi-automatic drain version

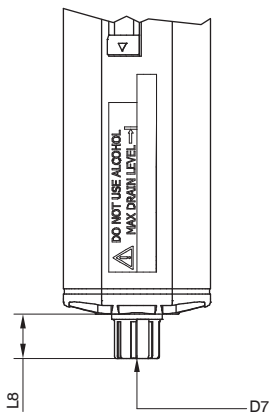

Automatic drain version

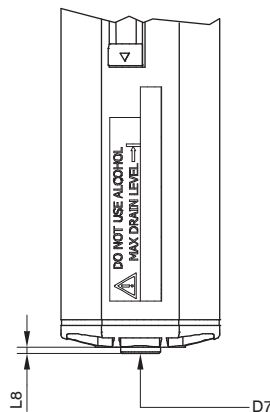

2

AIR TREATMENT

| Model | L8 - Bowl material | | D7 |
|----------------------|--------------------|-------|------------------------|
| | Technopolymer | Metal | |
| Semi-automatic drain | 15,7 | 18 | Plastic hose connector |
| Automatic drain | 2 | 4,5 | G1/8" |

Oil removal filters (DBV - DCV - DAV)



- ▶ Oil removal filter with coalescing filter element
- ▶ Available in 2 sizes with connections from 3/8" to 1"
- ▶ Particle removal up to 0,01 μm
- ▶ Oil residual 0,01 ppm
- ▶ Cartridge clogging level display:
 - green color - ok
 - red color - warning ($\Delta p > 0,5$ bar)
- ▶ Bowl assembly via bayonet type quick coupling mechanism with safety button
- ▶ Automatic drain mounted as standard
- ▶ Atex certification (II 2GD or II 3GD)

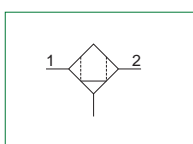

Note

In order to ensure the high level of filtration, it is recommended that a 5μ filter is installed before the coalescing filter. In order to ensure that any fluid discharged by the auto drain assembly is adequately drained away, it is recommended you use a 6mm fitting and tube.

| Technical characteristics | | | |
|--|------------------|---|--------------------|
| Size | | Size 3 | Size 4 |
| Body and connections type | | Technopolymer body, integrated technopolymer connections (T version) Technopolymer body, metal connections (N version) Aluminium body, integrated aluminium connections (P version) | |
| Protection and bowl type | | Technopolymer protection - PC bowl Technopolymer protection - PA bowl Metal protection - PC bowl Metal protection - PA bowl Metal bowl (blind metal bowl) | |
| IN / OUT connections | T version | G1/2" | not available |
| | N version | G3/8" - G1/2" - 1/2" NPT | |
| | P version | G1/2" | G1" |
| Assembly configuration | | Stand alone | Panel mounted |
| Assembly positions | | Vertical ±5° | |
| Filter pore size | | Particle removal up to 0,01 μm Oil residual 0,01 ppm | |
| Bowl capacity | | 30 cm ³ | 90 cm ³ |
| Condensation drain | | Automatic | |
| Max. fittings torque IN / OUT connections | | G3/8" metal: 25Nm G1/2" metal: 30Nm G1/2" technopolymer: 22Nm | G1" metal: 35Nm |

| Operational characteristics | | |
|---------------------------------|------------------|--------|
| Size | Size 3 | Size 4 |
| Condensation drain | Automatic | |
| Maximum working pressure | 10 bar | |
| Minimum working pressure | 0,5 bar | |
| Working temperature | -5°C +50°C | |

| Weights | | | | |
|--|------|------------------------------|------------------------------|--------|
| | Size | Size 3 Standard cartridge | Size 3 Oversize cartridge | Size 4 |
| Fully technopolymer version | | 416 g | 634 g | / |
| Technopolymer body version, aluminium bowl protection and technopolymer bowl | | 453 g | 671 g | / |
| Technopolymer body version, aluminium bowl | | 526 g | 742 g | / |
| Aluminium body version, technopolymer protection and bowl | | 538 g | 661 g | 1230 g |
| Aluminium body version, aluminium bowl protection and technopolymer bowl | | 575 g | 698 g | 1374 g |
| Aluminium body version and aluminium bowl | | 647 g | 769 g | 1398 g |

Materials

Exploded sectioned

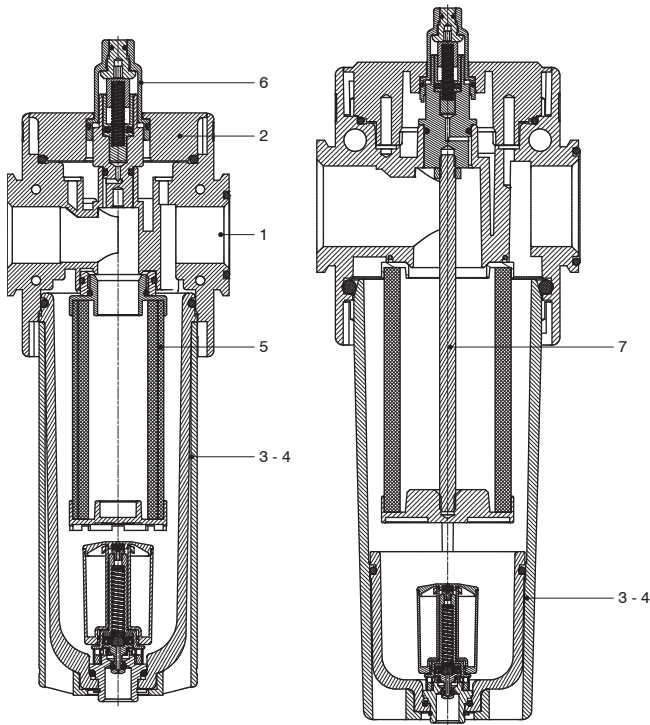

| Oil removal filter | | |
|--------------------|-------------------------------|--|
| 1 | Body | Polyamide Die-cast aluminium |
| 2 | Upper plug | Polyamide |
| 3 | Technopolymer bowl | Polycarbonate Polyamide |
| 4 | Metal bowl Bowl protection | Die-cast aluminium Polyamide - Die-cast aluminium |
| 5 | Filtering element | / |
| 6 | Visual indicator | Polycarbonate |
| 7 | Tie rod | Steel (only for size 4) |
| 8 | Automatic drain | / |

2
AIR TREATMENT

Design

Size 3
Technopolymer protection

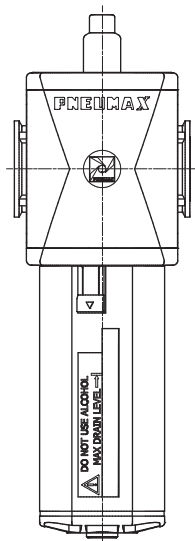

Size 3
Protection / Metal bowl

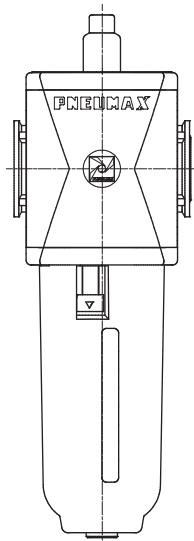

Size 3 - Oversize cartridge
Technopolymer protection

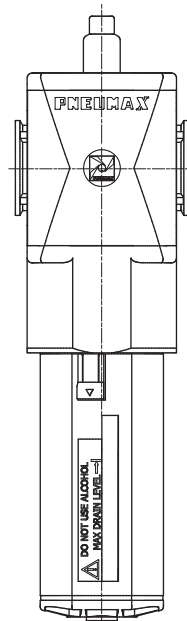

Size 4
All versions

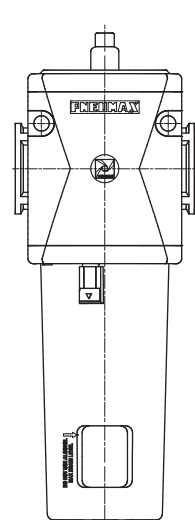

Order codes

T 17 3BDBV T

| Version |
|---|
| N : Technopolymer body and metal inserts (not available for size 4) |
| T : Technopolymer body and thread (not available for size 4) |
| P : Aluminium body |

| Size and connections |
|---|
| 3ADBV : Size 3 - G3/8" standard cartridge only for N version |
| 3BDBV : Size 3 - G1/2" standard cartridge for all versions |
| 3CDBV : Size 3 - 1/2" NPT standard cartridge only for N version |
| 3BDCV : Size 3 - G1/2" oversize cartridge only for P version |
| 4BDAV : Size 4 - G1" standard cartridge only for P version |

| Bowl options |
|--|
| : Technopolymer protection - PC bowl |
| N : Technopolymer protection - PA bowl |
| P : Metal protection - PC bowl |
| R : Metal protection - PA bowl |
| T : Metal bowl |

Example : T173BDBVT : Size 3 oil removal filter G1/2", standard cartridge, metal bowl

Characteristic curves

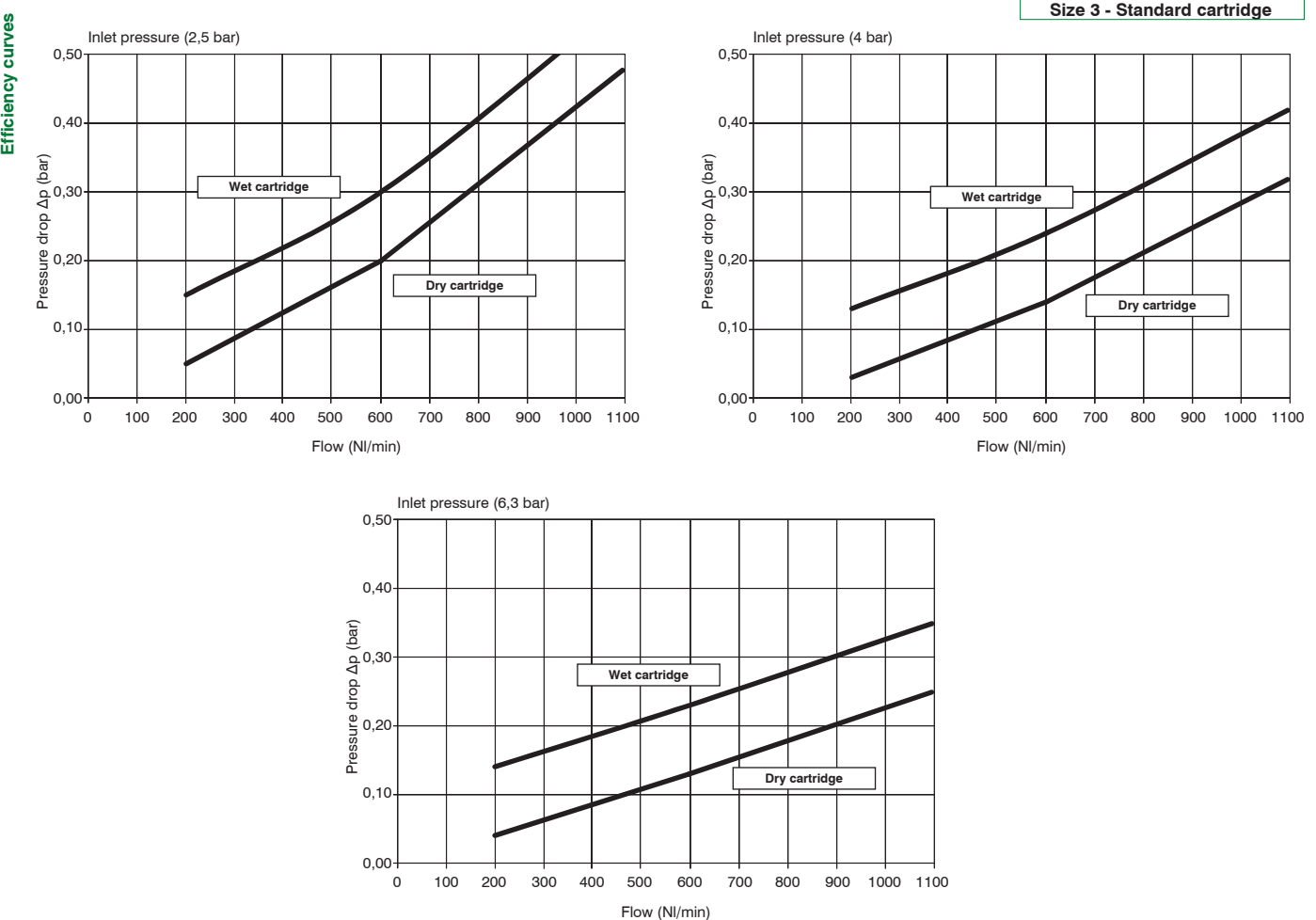



Size 3 - Oversize cartridge

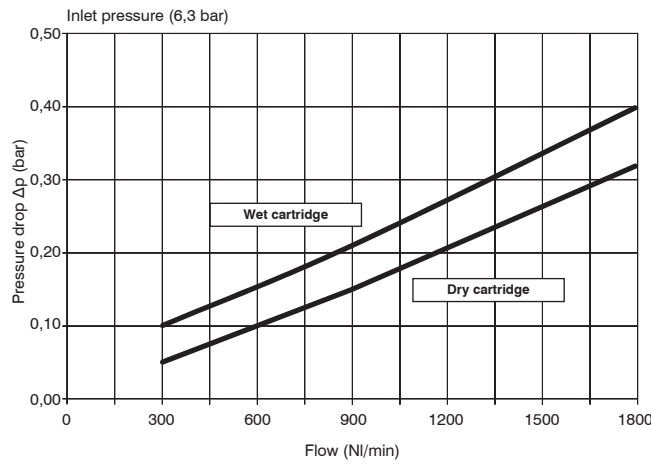
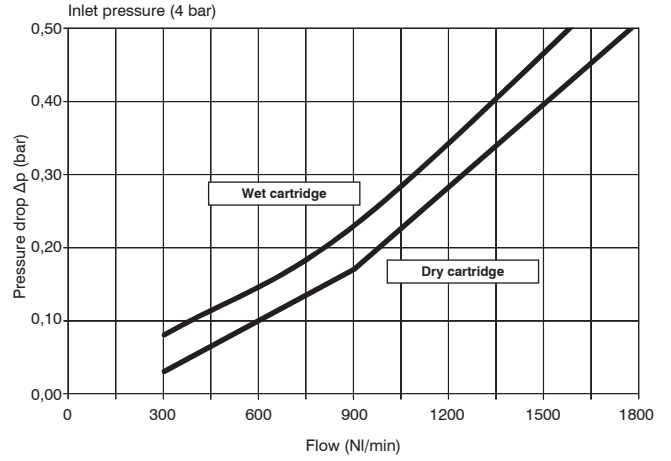
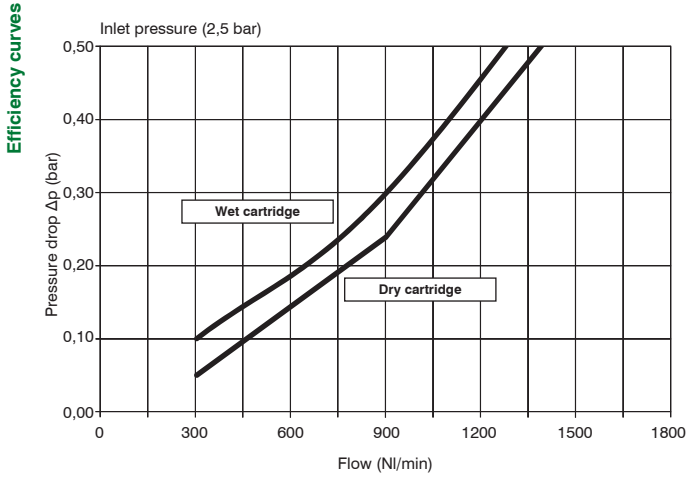

Size 4 - Standard cartridge

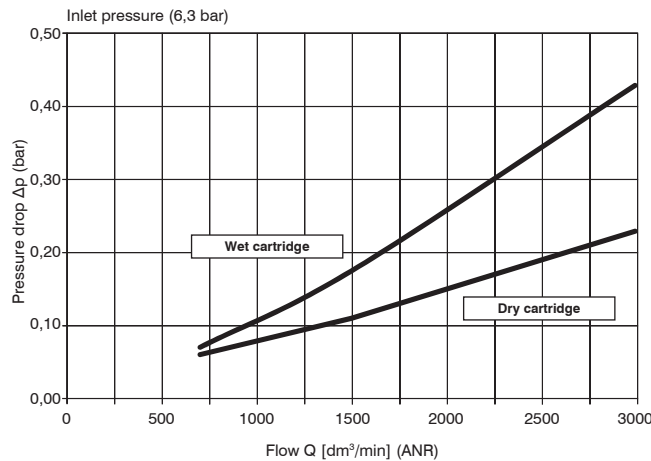
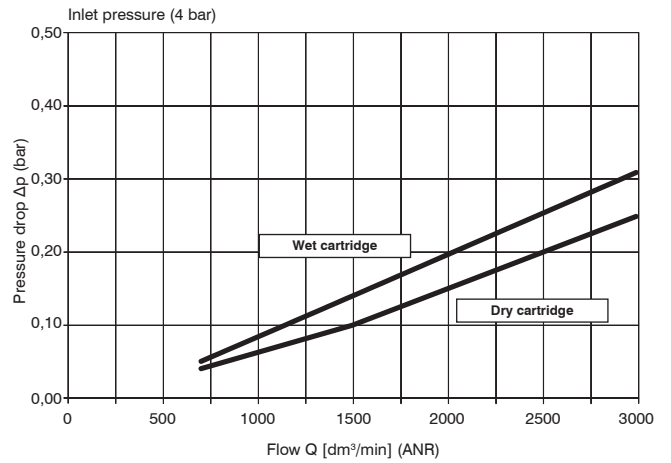
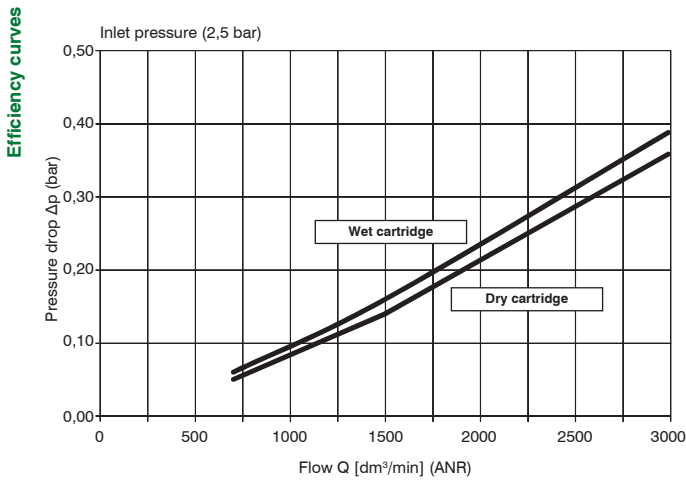

Dimensions

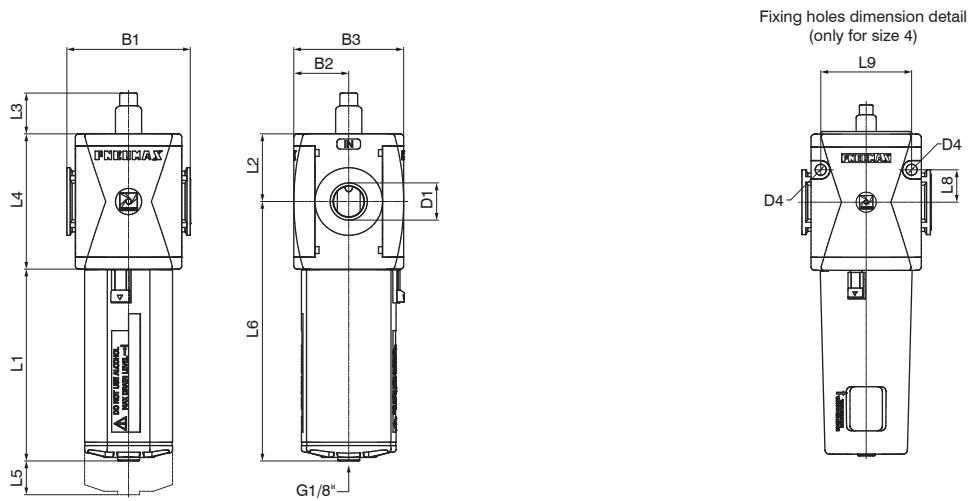

| Model | B1 | B2 | B3 | D1 | | L1 - Bowl material | | L3 | L4 | | L5 | L8 | L9 |
|--------|----|------|----|----------------------------|--------------------|--------------------|-------|------|--------------------|--------------------|-----|----|----|
| | | | | Standard cartridge | Oversize cartridge | Technopolymer | Metal | | Standard cartridge | Oversize cartridge | | | |
| #173.. | 73 | 32,5 | 65 | G3/8" G1/2" 1/2" NPT | G1/2" | 113,5 | 116 | 24,1 | 80 | 118 | 65 | / | / |
| #174.. | 99 | 44 | 88 | G1" | / | 143 | 145,5 | 22,5 | 105 | / | 103 | 25 | 70 |

► Carbon filters (DD)



- ▶ Carbon filter
- ▶ Available in 2 sizes with connections from 3/8" to 1"
- ▶ Active carbon cartridge with built in particulate filter
- ▶ Used to remove oil vapours, hydrocarbons, odours and particles
- ▶ Oil residue up to <0,003 ppm (max input aerosol 0.01 ppm)
- ▶ High absorption capacity, with low differential pressure
- ▶ Filtering performances 99.97% (particles up to 0.01 μm)
- ▶ Bowl assembly via bayonet type quick coupling mechanism with safety button
- ▶ Semi-automatic drain
- ▶ Atex certification (II 2GD or II 3GD)
- ▶ Inlet pressures up to 20 bar

2

AIR TREATMENT

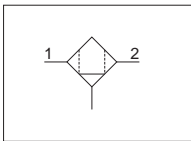

Note

A 5μ filter, coalescing filter and oil removing filter must be installed prior to the carbon filter, this is to ensure that the carbon filter operates correctly and safe guard the life of the active carbon element. It may also be necessary to replace the carbon element at fixed intervals.

| Technical characteristics | | |
|--|---|--------------------------|
| Size | Size 3 | Size 4 |
| Body and connections type | Technopolymer body, integrated technopolymer connections (T version) Technopolymer body, metal connections (N version) | / / |
| | Aluminium body, integrated aluminium connections (P - L versions) | |
| Protection and bowl type | Technopolymer protection - PC bowl Technopolymer protection - PA bowl Metal protection - PC bowl Metal protection - PA bowl Metal bowl (blind metal bowl) | |
| IN / OUT connections | T version | G1/2" |
| | N version | G3/8" - G1/2" - 1/2" NPT |
| | P and L version | G1/2" |
| Assembly configuration | Stand alone | Panel mounted |
| Assembly positions | Vertical ±5° | |
| Oil residue | < 0,003 ppm (max input aerosol 0.01 ppm) | |
| Bowl capacity | 68 cm ³ | 90 cm ³ |
| Condensation drain | Semi-automatic | |
| Max. fittings torque IN / OUT connections | G3/8" metal: 25Nm G1/2" metal: 30Nm G1/2" technopolymer: 22Nm | G1"metal: 35Nm |

| Operational characteristics | | |
|---------------------------------|--|--------|
| Size | Size 3 | Size 4 |
| Condensation drain | Semi-automatic | |
| Maximum working pressure | 13 bar 20 bar (only with body and metal bowl) | |
| Minimum working pressure | 0,5 bar | |
| Working temperature | -5°C +50°C -30°C +80°C (only for P version and metal bowl) -40°C +80°C (only for L version and metal bowl) | |
| Cartridge life | 2000 hours | |

| Weights | | | |
|--|------|--------|--------|
| | Size | Size 3 | Size 4 |
| Fully technopolymer version | | 395 g | / |
| Technopolymer body version, aluminium bowl protection and technopolymer bowl | | 432 g | / |
| Technopolymer body version, aluminium bowl | | 505 g | / |
| Aluminium body version, technopolymer protection and bowl | | 518 g | 1201 g |
| Aluminium body version, aluminium bowl protection and technopolymer bowl | | 554 g | 1344 g |
| Aluminium body version and aluminium bowl | | 628 g | 1368 g |

Materials

Exploded sectioned

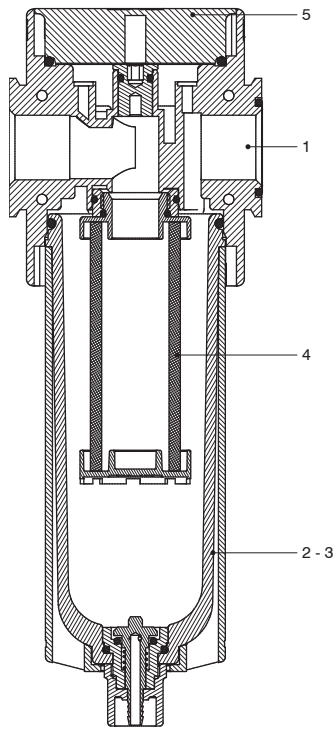

| Carbon filter | | |
|---------------|-------------------------------|--|
| 1 | Body | Polyamide Die-cast aluminium |
| 2 | Technopolymer bowl | Polycarbonate Polyamide |
| 3 | Metal bowl Bowl protection | Die-cast aluminium Polyamide - Die-cast aluminium |
| 4 | Filtering element | Activated carbon |
| 5 | Plug | Polyamide Die-cast aluminium |

2

AIR TREATMENT

Design

Size 3
Technopolymer protection

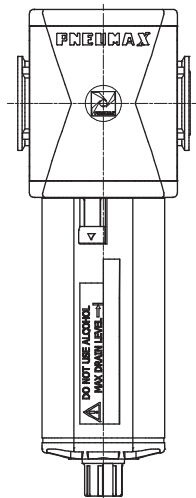

Size 3
Protection / Metal bowl

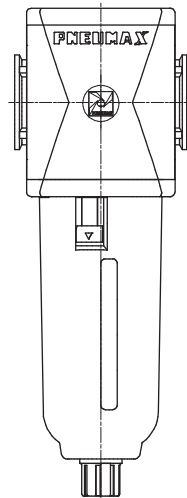

Size 4
All versions

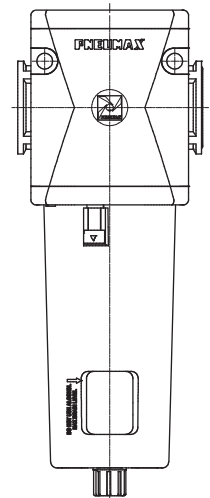



Order codes

T 17 3B DD T

| Version |
|---|
| N : Technopolymer body and metal inserts (not available for size 4) |
| T : Technopolymer body and thread (not available for size 4) |
| P : Aluminium body |
| L : Aluminium body, low temperature |

| Size and connections |
|---|
| 3A : Size 3 - G3/8" only for N version |
| 3B : Size 3 - G1/2" for all versions |
| 3C : Size 3 - 1/2" NPT only for N version |
| 4B : Size 4 - G1" only for P - L versions |

| Bowl options |
|--|
| : Technopolymer protection - PC bowl |
| N : Technopolymer protection - PA bowl |
| P : Metal protection - PC bowl |
| R : Metal protection - PA bowl |
| T : Metal bowl |

Example : T173BDDT : Size 3 carbon filter G1/2" metal bowl

2
AIR TREATMENT

Characteristic curves

Size 3

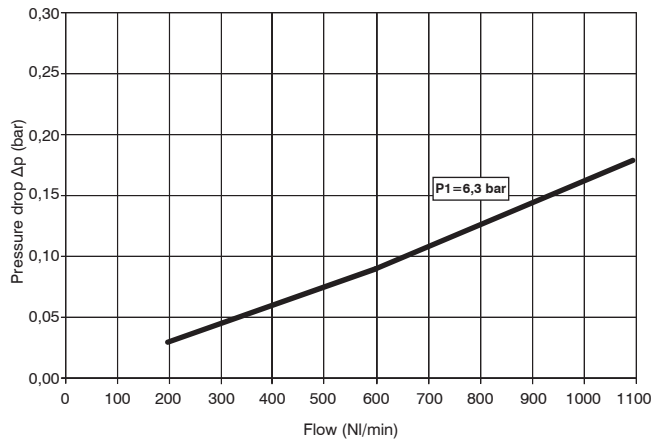
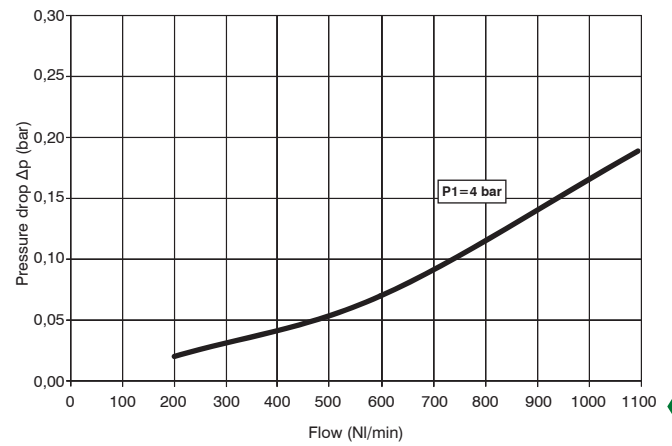
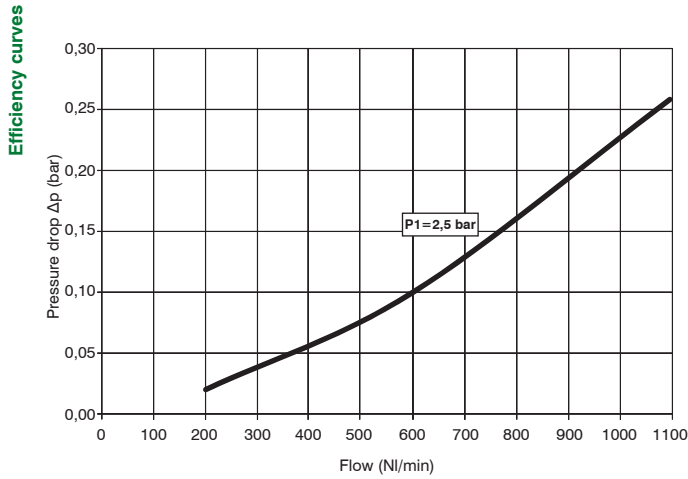

Size 4

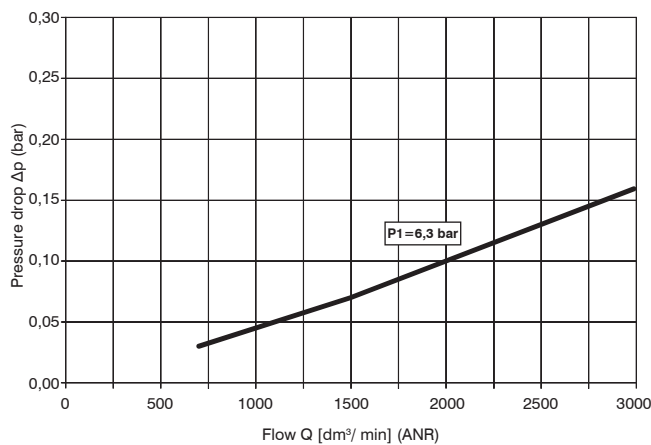
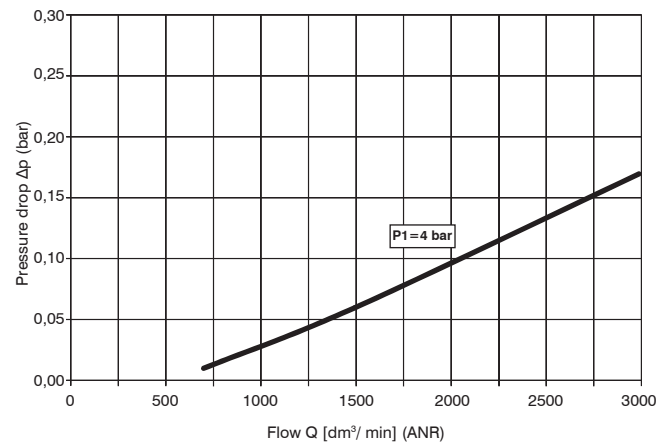
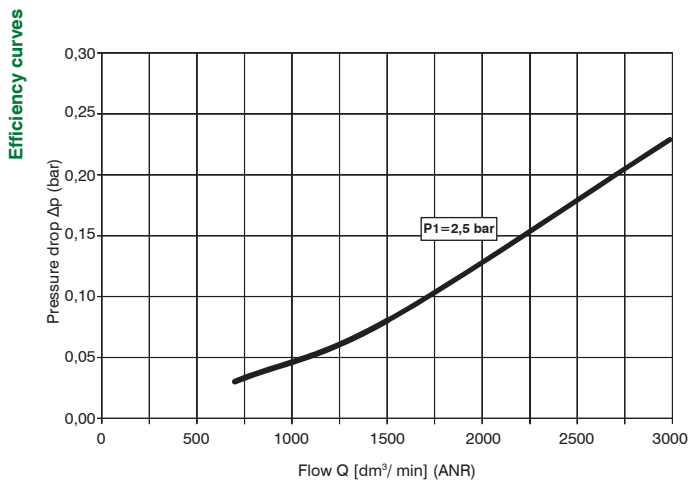

2

AIR TREATMENT



Dimensions

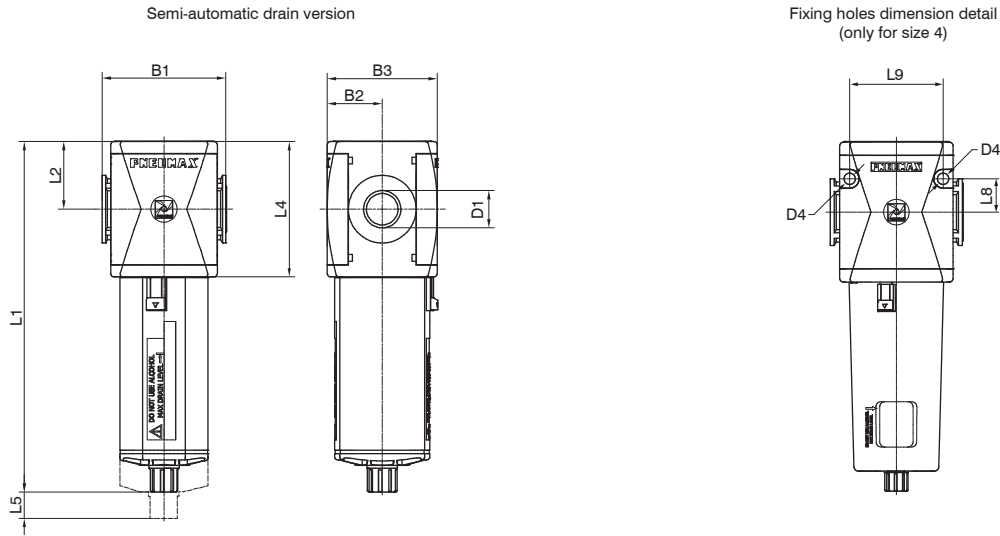

2 AIR TREATMENT

| Model | B1 | B2 | B3 | D1 | D4 | L1 - Bowl material | | L2 | L4 | L5 | L8 | L9 |
|--------|----|------|----|----------------------------|-----|--------------------|-------|------|-----|-----|----|----|
| | | | | | | Technopolymer | Metal | | | | | |
| #173.. | 73 | 32,5 | 65 | G3/8" G1/2" 1/2" NPT | / | 207,2 | 209,5 | 40 | 80 | 65 | / | / |
| #174.. | 99 | 44 | 88 | G1" 1" NPT | 8,5 | 262 | 264,5 | 52,5 | 105 | 103 | 25 | 70 |

Variable dimensions

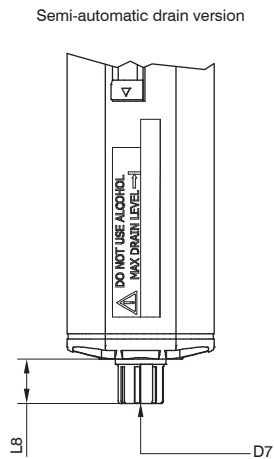

| Model | L8 - Bowl material | | D7 |
|----------------------|--------------------|-------|------------------------|
| | Technopolymer | Metal | |
| Semi-automatic drain | 15,7 | 18 | Plastic hose connector |



Filter regulators (E - EM - EW - EP - EZ)



- ▶ Filter - diaphragm pressure regulator with relieving
- ▶ Available in 4 sizes with flow rates up to 8000 NI/min and connections from 1/8" to 1"
- ▶ Low hysteresis rolling diaphragm and balanced spool
- ▶ Filtering element made of HDPE available in 3 different filtration grades (5µm, 20µm and 50µm)
- ▶ Bowl assembly via bayonet type quick coupling mechanism with safety button
- ▶ Semi-automatic or automatic drain
- ▶ Available in four pressure ranges up to 12 bar
- ▶ Fitted with panel mounting locking ring
- ▶ Available with pressure gauge or digital pressure switch integrated
- ▶ Atex certification (II 2GD or II 3GD)
- ▶ Inlet pressures up to 20 bar

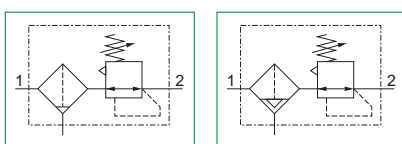

Note
For installations where a more accurate and constant pressure is required, the unit should be installed as close as possible to the point of use. In order to ensure that any fluid discharged by the auto drain assembly is adequately drained away, it is recommended you use a 6mm fitting and tube.

| Technical characteristics | | Size | Size 1 | Size 2 | Size 3 | Size 4 |
|---|------------------------|------|---|---|---|--------------------|
| Body and connections type | | | Technopolymer body, integrated technopolymer connections (T version) Technopolymer body, metal connections (N version) | Aluminium body, integrated aluminium connections (P - L versions) | | / |
| Protection and bowl type | | | Technopolymer protection - PC bowl Technopolymer protection - PA bowl | Metal protection - PC bowl Metal protection - PA bowl Metal bowl (blind metal bowl) | | / |
| IN / OUT connections | T version | | G1/4" | G3/8" | G1/2" | not available |
| | N version | | G1/8" - G1/4" - 1/4" NPT | G3/8" - G1/4" - 3/8" NPT | G3/8" - G1/2" - 1/2" NPT | |
| | P and L version | | not available | G3/8" - 1/4" NPT | G1/2" - 1/2" NPT | G1" - 1" NPT |
| Assembly configuration | | | Stand alone Panel mounting With fixing bracket / | | | Panel mounted |
| Assembly positions | | | Vertical ±5° | | | |
| Filter pore size | | | 5 µm 20 µm 50 µm | | | |
| Pressure range | | | 0-2 bar 0-4 bar 0-8 bar 0-12 bar (P2 max 10 Bar in case of digital pressure switch selection) | | | |
| Bowl capacity | | | 18 cm ³ | 34 cm ³ | 68 cm ³ | 90 cm ³ |
| Condensation drain | | | Semi-automatic Automatic | | | |
| Regulation | | | Manul push and lock with pressure Manual lockable with accessories | | | |
| Pressure measurement | | | G1/8" - 1/8" NPT pressure gauge connection port (only for versions with IN / OUT NPT connections) Integrated pressure gauge (optional) Digital pressure switch (optional) | | | |
| Max. fittings torque IN / OUT connections | | | G1/8" metal: 15Nm G1/4" metal: 20Nm G1/4" technopolymer: 9Nm | G1/4" metal: 20Nm G3/8" metal: 25Nm G3/8" technopolymer: 16Nm | G3/8" metal: 25Nm G1/2" metal: 30Nm G1/2" technopolymer: 22Nm | G1" metal: 35Nm |
| Max. fitting torque pressure gauge connection port | | | G1/8" technopolymer: 4Nm G1/8" metal: 15Nm | | | |

| Operational characteristics | | | | | | | | |
|---|----------------|--|--|--------|------------|--|--------|--------|
| Size | Size 1 | Size 2 | Size 3 | Size 4 | Size 1 | Size 2 | Size 3 | Size 4 |
| Condensation drain | Semi-automatic | | | | Automatic | | | |
| Maximum working pressure | 13 bar | 20 bar (only with body and metal bowl) | | | 10 bar | 16 bar (only with body and metal bowl) | | |
| Minimum working pressure | 0,5 bar | | | | 0,5 bar | | | |
| Working temperature | -5°C +50°C | | -30°C +80°C (only for P version and metal bowl) -40°C +80°C (only for L version and metal bowl) | | -5°C +50°C | | | |
| Working temperature with digital pressure switch | 0°C +50°C | | | | | | | |

| Weights | | | | | |
|--|------|--------|--------|--------|--------|
| | Size | Size 1 | Size 2 | Size 3 | Size 4 |
| Fully technopolymer version | | 210 g | 410 g | 500 g | / |
| Technopolymer body version, aluminium bowl protection and technopolymer bowl | | / | 440 g | 600 g | / |
| Technopolymer body version, aluminium bowl | | / | 460 g | 660 g | / |
| Aluminium body version, technopolymer protection and bowl | | / | 480 g | 710 g | 1460 g |
| Aluminium body version, aluminium bowl protection and technopolymer bowl | | / | 510 g | 730 g | 1600 g |
| Aluminium body version and aluminium bowl | | / | 560 g | 790 g | 1620 g |

Materials

Exploded sectioned

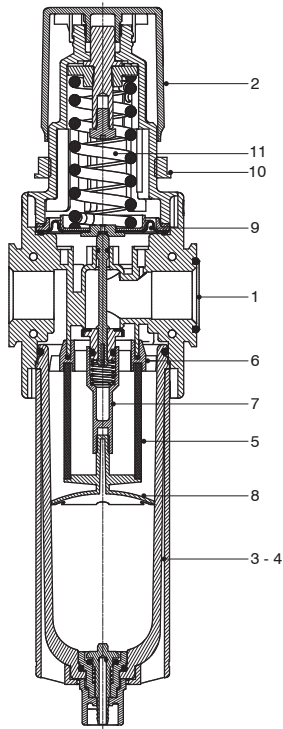

| Filter regulator | | |
|------------------|-------------------------------|--|
| 1 | Body | Polyamide Die-cast aluminium |
| 2 | Adjusting knob | Polyamide |
| 3 | Technopolymer bowl | Polycarbonate Polyamide |
| 4 | Metal bowl Bowl protection | Die-cast aluminium Polyamide - Die-cast aluminium |
| 5 | Filtering element | Polyethylene |
| 6 | Baffle | Acetal resin |
| 7 | Spool support | Acetal resin |
| 8 | Filtering element support | Acetal resin |
| 9 | Diaphragm | NBR |
| 10 | Panel mounting locking ring | Polyamide |
| 11 | Adjusting spring | Steel |

2
AIR TREATMENT

Design

Size 1 - Size 2 - Size 3
Technopolymer protection

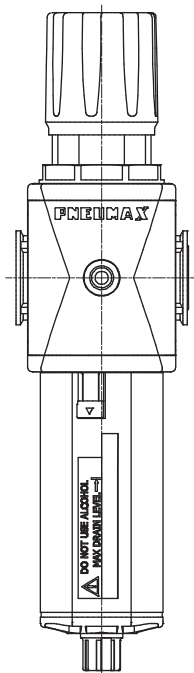

Size 1 - Size 2 - Size 3
Protection / Metal bowl

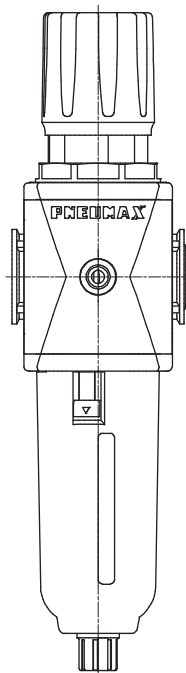

Size 4
All versions

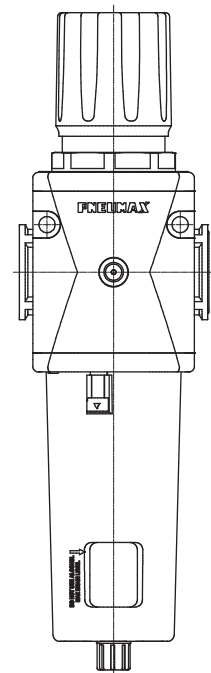



Order codes

| | | | | | | | | | | | | |
|--|---|----|----|---|---|---|---|---|--|--|--|---|
| | T | 17 | 3B | E | M | B | D | S | | | | T |
| Version | | | | | | | | | | | | |
| N : Technopolymer body and metal inserts (not available for size 4) | | | | | | | | | | | | |
| T : Technopolymer body and thread (not available for size 4) | | | | | | | | | | | | |
| P : Aluminum body (not available for size 1) | | | | | | | | | | | | |
| L : Aluminum body, low temperature (not available for size 1) | | | | | | | | | | | | |
| Size and connections | | | | | | | | | | | | |
| 1A : Size 1 - G1/8" only for N version | | | | | | | | | | | | |
| 1B : Size 1 - G1/4" only for T - N versions | | | | | | | | | | | | |
| 1C : Size 1 - 1/4" NPT only for N version | | | | | | | | | | | | |
| 2A : Size 2 - G1/4" only for N version | | | | | | | | | | | | |
| 2B : Size 2 - G3/8" for all versions | | | | | | | | | | | | |
| 2C : Size 2 - 3/8" NPT only for N version - 1/4" NPT only for P - L versions | | | | | | | | | | | | |
| 3A : Size 3 - G3/8" only for N version | | | | | | | | | | | | |
| 3B : Size 3 - G1/2" for all versions | | | | | | | | | | | | |
| 3C : Size 3 - 1/2" NPT only for N - P - L versions | | | | | | | | | | | | |
| 4B : Size 4 - G1" only for P - L versions | | | | | | | | | | | | |
| 4C : Size 4 - 1" NPT only for P - L versions | | | | | | | | | | | | |
| Pressure measurement options | | | | | | | | | | | | |
| : G1/8" - 1/8" NPT thread | | | | | | | | | | | | |
| M : Integrated pressure gauge | | | | | | | | | | | | |
| W : Integrated pressure gauge Right - Left | | | | | | | | | | | | |
| P : Digital pressure switch | | | | | | | | | | | | |
| Z : Digital pressure switch Right - Left | | | | | | | | | | | | |
| Filter pore size | | | | | | | | | | | | |
| A : 5 μm | | | | | | | | | | | | |
| B : 20 μm | | | | | | | | | | | | |
| C : 50 μm | | | | | | | | | | | | |
| Pressure range | | | | | | | | | | | | |
| A : 0 - 2 bar | | | | | | | | | | | | |
| B : 0 - 4 bar | | | | | | | | | | | | |
| C : 0 - 8 bar | | | | | | | | | | | | |
| D : 0 - 12 bar | | | | | | | | | | | | |
| Condensation drain | | | | | | | | | | | | |
| : Semi-automatic drain | | | | | | | | | | | | |
| S : Automatic drain | | | | | | | | | | | | |
| Relieving options | | | | | | | | | | | | |
| : With relieving | | | | | | | | | | | | |
| L : Without relieving | | | | | | | | | | | | |
| Knob options | | | | | | | | | | | | |
| : Non-lockable version | | | | | | | | | | | | |
| K : Lockable version | | | | | | | | | | | | |
| U : Lockable version with universal key | | | | | | | | | | | | |
| Digital pressure switch options | | | | | | | | | | | | |
| A : Cable 150 mm + M8 PNP | | | | | | | | | | | | |
| B : Cable 150 mm + M8 NPN | | | | | | | | | | | | |
| C : Cable 2 m PNP | | | | | | | | | | | | |
| D : Cable 2 m NPN | | | | | | | | | | | | |
| Bowl options | | | | | | | | | | | | |
| : Technopolymer protection - PC bowl | | | | | | | | | | | | |
| N : Technopolymer protection - PA bowl | | | | | | | | | | | | |
| P : Metal protection - PC bowl (not available for size 1) | | | | | | | | | | | | |
| R : Metal protection - PA bowl (not available for size 1) | | | | | | | | | | | | |
| T : Metal bowl (not available for size 1) | | | | | | | | | | | | |

Example : T173BEMBDST : Size 3 filter regulator G1/2" 20 μm 0 - 12 bar, automatic drain and metal bowl

2
AIR TREATMENT



Characteristic curves

AIR TREATMENT

2

Size 1 - G1/4" 0-8 bar P1=7 bar

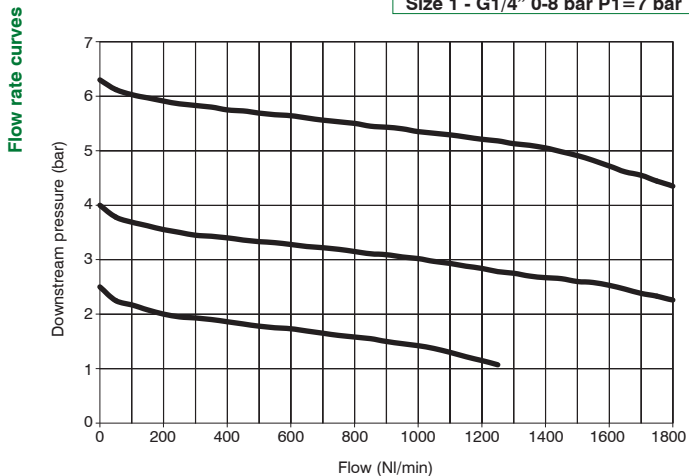

Adjustment characteristic

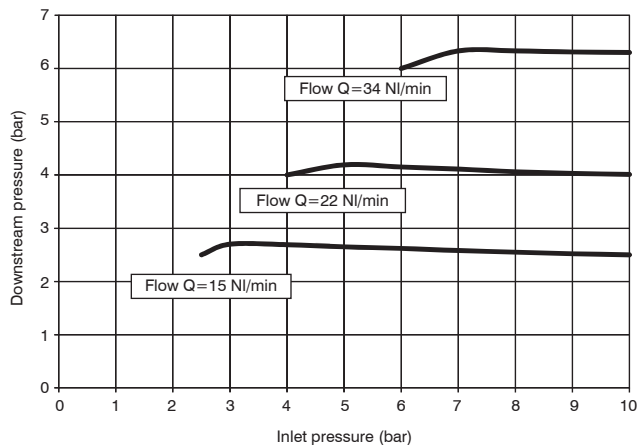

Size 2 - G3/8" 0-8 bar P1=7 bar

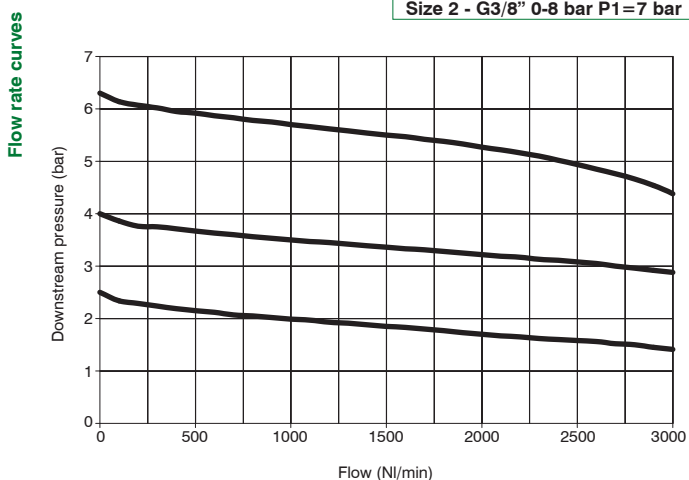

Adjustment characteristic

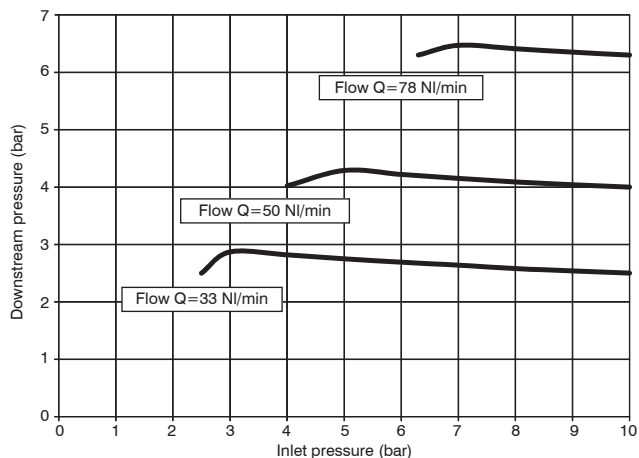

Size 3 - G1/2" 0-8 bar P1=7 bar

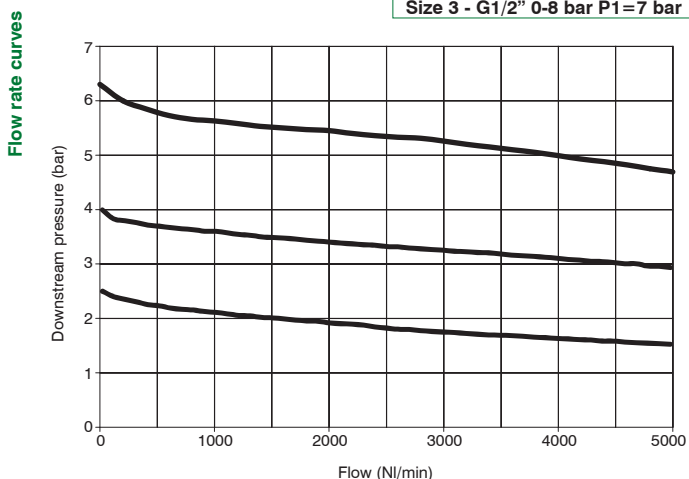

Adjustment characteristic

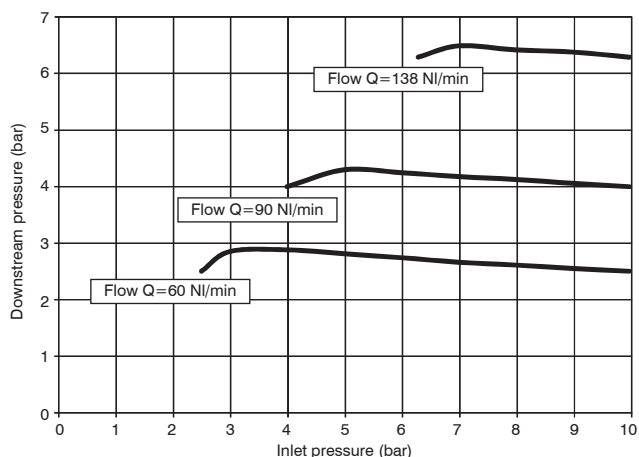

Size 4 - G1" 0-8 bar P1=10 bar

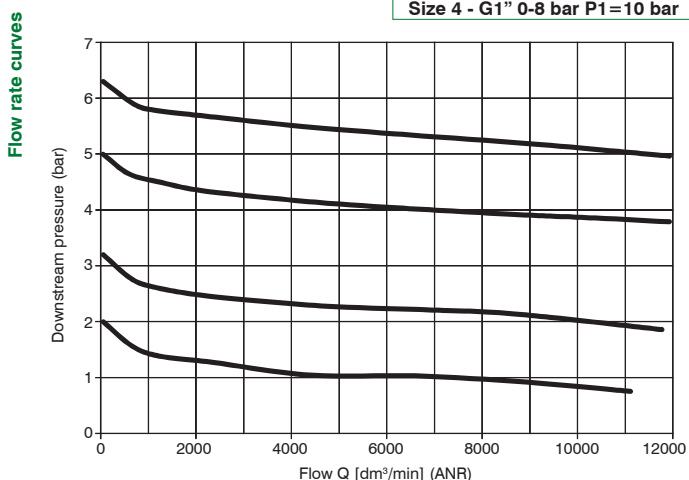

Adjustment characteristic

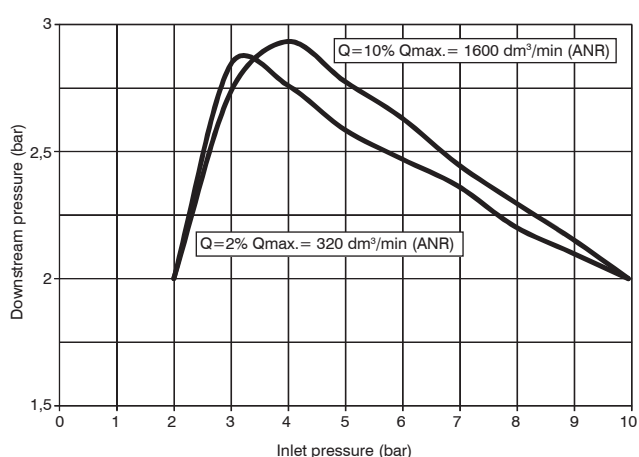

Dimensions

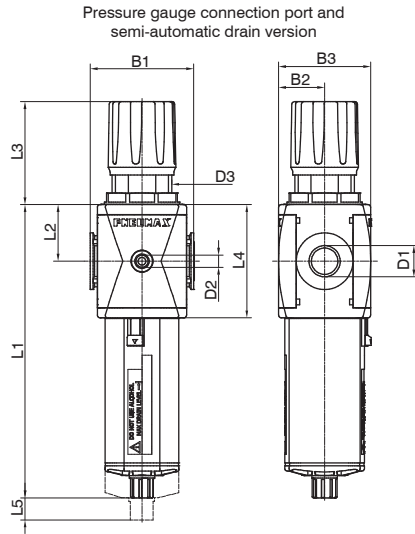

Fixing holes dimension detail (only for size 4)

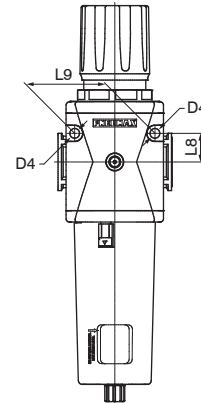

| Model | B1 | B2 | B3 | D1 | D2 | D3 | D4 | L1 - Bowl material | | L2 | L3 | L4 | L5 | L8 | L9 |
|--------|----|------|----|--|-------------------|---------|-----|--------------------|-------|------|------|-----|-----|----|----|
| | | | | | | | | Technopolymer | Metal | | | | | | |
| #171.. | 48 | 21 | 42 | G1/8" G1/4" 1/4" NPT | G1/8" 1/8" NPT | M30x1,5 | / | 148 | / | 27,5 | 54 | 55 | 40 | / | / |
| #172.. | 62 | 28,5 | 57 | G1/4" G3/8" 1/4" NPT 3/8" NPT | G1/8" 1/8" NPT | M42x1,5 | / | 169,1 | 171,5 | 34 | 71,8 | 68 | 50 | / | / |
| #173.. | 73 | 32,5 | 65 | G3/8" G1/2" 1/2" NPT | G1/8" 1/8" NPT | M42x1,5 | / | 207,2 | 209,5 | 40 | 72,8 | 80 | 65 | / | / |
| #174.. | 99 | 44 | 88 | G1" 1" NPT | G1/8" 1/8" NPT | M54x1,5 | 8,5 | 262 | 264,5 | 52,5 | 87,5 | 105 | 103 | 25 | 70 |

2

AIR TREATMENT

Variable dimensions

Integrated pressure gauge version

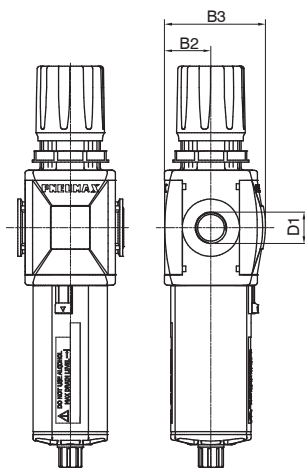

Integrated digital pressure switch version

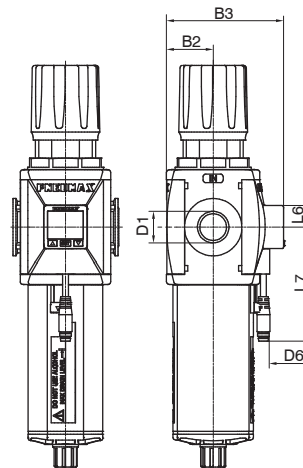

| Model | B2 | B3 | | D1 | D6 - Type of digital pressure switch | | L6 | L7 - Type of digital pressure switch | |
|--------|------|---------------------|------------------------------|--|--------------------------------------|------------------------|----|--------------------------------------|-------|
| | | With pressure gauge | With digital pressure switch | | A - B | C - D | | A - B | C - D |
| #171.. | 21 | 48,5 | 60 | G1/8" G1/4" 1/4" NPT | M8 - 3 PIN | 3 x 0,129 mm, Ø4 mm | 15 | 150 | 2000 |
| #172.. | 28,5 | 62,5 | 73,5 | G1/4" G3/8" 1/4" NPT 3/8" NPT | | | | | |
| #173.. | 32,5 | 70,5 | 81,5 | G3/8" G1/2" 1/2" NPT | | | | | |
| #174.. | 44 | 90,5 | 101,5 | G1" 1" NPT | | | | | |

Variable dimensions

Semi-automatic drain version

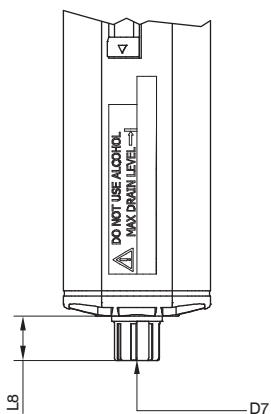

Automatic drain version

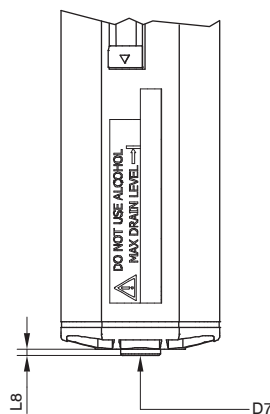

2

AIR TREATMENT

| Model | L8 - Bowl material | | D7 |
|----------------------|--------------------|-------|------------------------|
| | Technopolymer | Metal | |
| Semi-automatic drain | 15,7 | 18 | Plastic hose connector |
| Automatic drain | 2 | 4,5 | G1/8" |

Digital pressure switch



- ▶ 3 color digital LCD display, easy readout
- ▶ 4 units of measurement for pressure indication
- ▶ Optional PNP or NPN digital output
- ▶ N.O. and N.C. output contact selection directly on the digital pressure switch
- ▶ Available with M8-3PIN connector or 3 wire cable length 2 m
- ▶ Available only in combination with a filter regulator

Output circuit wiring diagrams

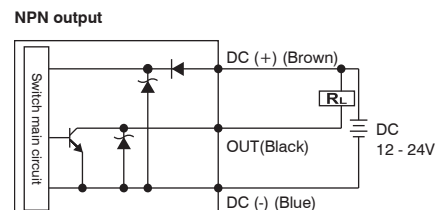
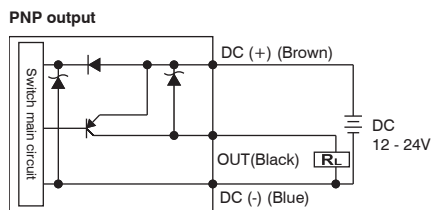

Digital pressure switch lay out

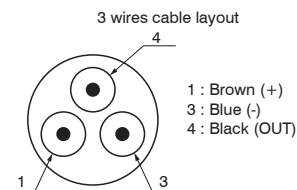
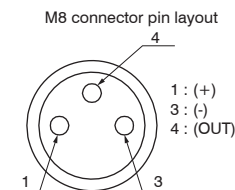

Cable ordering code

- MCH1** : cable 3 wires l=2,5m with M8 connector
- MCH2** : cable 3 wires l=5m with M8 connector
- MCH3** : cable 3 wires l=10m with M8 connector



| Technical characteristics | |
|--------------------------------|---|
| Pressure range and display | 0 - 10 bar |
| Max. inlet pressure | 15 bar |
| Fluid | 40µm filtered and dehumidified air |
| Display unit of measurement | MPa - kgf/cm² - bar - psi |
| Supply voltage | 12 - 24 VDC |
| Current consumption | ≤40mA (without load) |
| Digital output type | PNP - NPN |
| Type of contact output | Normally Open - Normally Closed |
| Max. load current | 125 mA |
| Digital output activation mode | single threshold with fixed hysteresis - window with fixed hysteresis - window without hysteresis |
| Digital output activation time | 0.05s - 0.25s - 0.5s - 1s - 2s - 3s (selections for chattering-proof options) |
| Display characteristics | Double 3 1/2 digit display Digital output status indication Three-pushbuttons touchpad |
| Indicator accuracy | ≤ ±2% full scale value ± 1 digit |
| IP Rating | IP40 |
| Working temperature | 0°C +50°C |
| Cable section | 3 x 0,129mm², Ø4 mm, PVC |

► **Fixing bracket**

T172 50

| Size |
|------------------------|
| 171 : Size 1 |
| T172 : Size 2 - Size 3 |

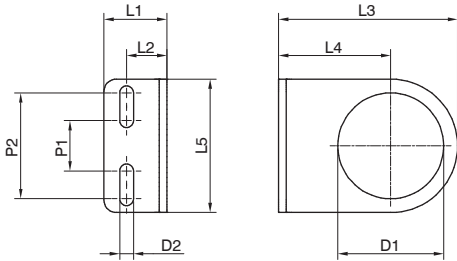

2

AIR TREATMENT

| Model | L1 | L2 | L3 | L4 | L5 | D1 | D2 | P1 | P2 |
|--------|----|----|----|------|----|----|-----|----|----|
| 17150 | 20 | 13 | 50 | 30 | 40 | 30 | 5,5 | 20 | 30 |
| T17250 | 25 | 16 | 71 | 44,5 | 53 | 42 | 5,5 | 20 | 42 |

► **Pressure gauge**

17070 A C

| Version |
|--------------|
| A : Dial Ø40 |
| B : Dial Ø50 |

| Scale |
|----------------|
| A : 0 - 4 bar |
| B : 0 - 6 bar |
| C : 0 - 12 bar |

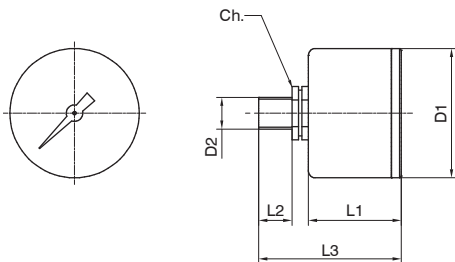

| Model | L1 | L2 | L3 | D1 | D2 | Ch |
|----------|----|----|----|----|-----------|----|
| 17070A.. | 26 | 10 | 44 | 41 | Gc - 1/8" | 14 |
| 17070B.. | 27 | 10 | 45 | 49 | Gc - 1/8" | 14 |



► Regulators (R - RM - RW - RP - RZ)



- Diaphragm pressure regulator with relieving
- Available in 4 sizes with flow rates up to 8000 NI/min and connections from 1/8" to 1"
- Low hysteresis rolling diaphragm and balanced spool
- Available in four pressure ranges up to 12 bar
- Fitted with panel mounting locking ring
- Available with pressure gauge or digital pressure switch integrated
- Atex certification (II 2GD or II 3GD)
- Inlet pressures up to 20 bar

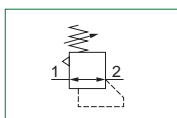

Note

For installations where a more accurate and constant pressure is required, the unit should be installed as close as possible to the point of use.

2

AIR TREATMENT

| Technical characteristics | | Size | Size 1 | Size 2 | Size 3 | Size 4 |
|---|------------------------|---|--------|---|--------|--|
| Body and connections type | | Technopolymer body, integrated technopolymer connections (T version) Technopolymer body, metal connections (N version) | | | | / |
| | | / | | Aluminium body, integrated aluminium connections (P - L versions) | | |
| IN / OUT connections | T version | G1/4" | | G3/8" | | G1/2" |
| | N version | G1/8" - G1/4" - 1/4" NPT | | G3/8" - G1/4" - 3/8" NPT | | G3/8" - G1/2" - 1/2" NPT |
| | P and L version | not available | | G3/8" - 1/4" NPT | | G1/2" - 1/2" NPT |
| Assembly configuration | | Stand alone Panel mounting With fixing bracket / | | | | Panel mounted |
| Assembly positions | | Indifferent | | | | |
| Pressure range | | 0-2 bar 0-4 bar 0-8 bar 0-12 bar (P2 max 10 Bar in case of digital pressure switch selection) | | | | |
| Regulation | | Manul push and lock with pressure Manual lockable with accessories | | | | |
| Pressure measurement | | G1/8" - 1/8" NPT pressure gauge connection port (only for versions with IN / OUT NPT connections) Integrated pressure gauge (optional) Digital pressure switch (optional) | | | | |
| Max. fittings torque IN / OUT connections | | G1/8" metal: 15Nm G1/4" metal: 20Nm G1/4" technopolymer: 9Nm | | G1/4" metal: 20Nm G3/8" metal: 25Nm G3/8" technopolymer: 16Nm | | G3/8" metal: 25Nm G1/2" metal: 30Nm G1/2" technopolymer: 22Nm G1" metal: 35Nm |
| Max. fitting torque pressure gauge connection port | | G1/8" technopolymer: 4Nm G1/8" metal: 15Nm | | | | |

| Operational characteristics | | Size | Size 1 | Size 2 | Size 3 | Size 4 |
|---|--|------------|--------|--|--------|--------|
| Maximum working pressure | | 13 bar | | 20 bar (only for P - L versions) | | |
| Minimum working pressure | | 0,5 bar | | | | |
| Working temperature | | -5°C +50°C | | -30°C +80°C (only for P version) -40°C +80°C (only for L version) | | |
| Working temperature with digital pressure switch | | 0°C +50°C | | | | |



| Weights | | | | | |
|----------------------------|------|--------|--------|--------|--------|
| | Size | Size 1 | Size 2 | Size 3 | Size 4 |
| Technopolymer body version | | 150 g | 310 g | 390 g | / |
| Aluminium body version | | / | 400 g | 560 g | 1260 g |

Materials

Exploded sectioned

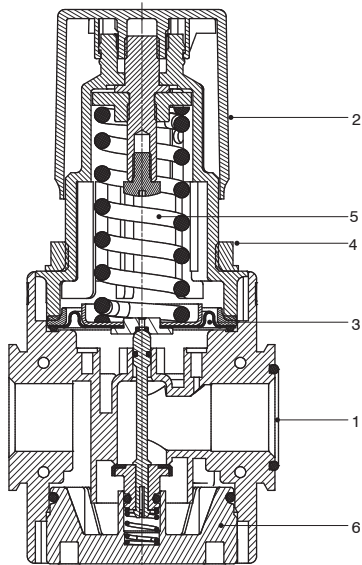

| Regulator | | |
|-----------|-----------------------------|---------------------------------|
| 1 | Body | Polyamide Die-cast aluminium |
| 2 | Adjusting knob | Polyamide |
| 3 | Diaphragm | NBR |
| 4 | Panel mounting locking ring | Polyamide |
| 5 | Adjusting spring | Steel |
| 6 | Rear end cap | Polyamide / Die-cast aluminium |

2

AIR TREATMENT

Design

Size 1 - Size 2 - Size 3

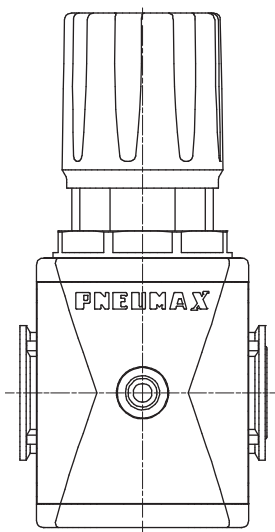

Size 4
All versions

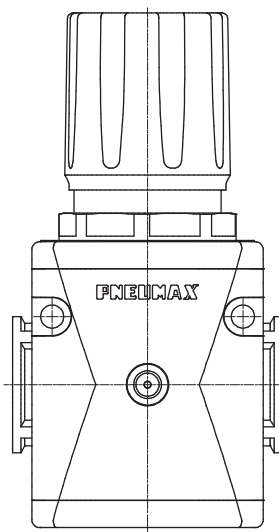



Order codes

| | | | | | | | | | |
|--|---|----|----|---|---|---|--|--|--|
| | T | 17 | 3B | R | M | D | | | |
| Version | | | | | | | | | |
| N : Technopolymer body and metal inserts (not available for size 4) | | | | | | | | | |
| T : Technopolymer body and thread (not available for size 4) | | | | | | | | | |
| P : Aluminum body (not available for size 1) | | | | | | | | | |
| L : Aluminum body, low temperature (not available for size 1) | | | | | | | | | |
| Size and connections | | | | | | | | | |
| 1A : Size 1 - G1/8" only for N version | | | | | | | | | |
| 1B : Size 1 - G1/4" only for T - N versions | | | | | | | | | |
| 1C : Size 1 - 1/4" NPT only for N version | | | | | | | | | |
| 2A : Size 2 - G1/4" only for N version | | | | | | | | | |
| 2B : Size 2 - G3/8" for all versions | | | | | | | | | |
| 2C : Size 2 - 3/8" NPT only for N version - 1/4" NPT only for P - L versions | | | | | | | | | |
| 3A : Size 3 - G3/8" only for N version | | | | | | | | | |
| 3B : Size 3 - G1/2" for all versions | | | | | | | | | |
| 3C : Size 3 - 1/2" NPT only for N - P - L versions | | | | | | | | | |
| 4B : Size 4 - G1" only for P - L versions | | | | | | | | | |
| 4C : Size 4 - 1" NPT only for P - L versions | | | | | | | | | |
| Pressure measurement options | | | | | | | | | |
| : G1/8" - 1/8" NPT thread | | | | | | | | | |
| M : Integrated pressure gauge | | | | | | | | | |
| W : Integrated pressure gauge Right - Left | | | | | | | | | |
| P : Digital pressure switch | | | | | | | | | |
| Z : Digital pressure switch Right - Left | | | | | | | | | |
| Pressure range | | | | | | | | | |
| A : 0 - 2 bar | | | | | | | | | |
| B : 0 - 4 bar | | | | | | | | | |
| C : 0 - 8 bar | | | | | | | | | |
| D : 0 - 12 bar | | | | | | | | | |
| Relieving options | | | | | | | | | |
| : With relieving | | | | | | | | | |
| F : Controlled refiel and improved relieving (not available for size 4) | | | | | | | | | |
| L : Without relieving | | | | | | | | | |
| R : Improved relieving | | | | | | | | | |
| Knob options | | | | | | | | | |
| : Non-lockable version | | | | | | | | | |
| K : Lockable version | | | | | | | | | |
| U : Lockable version with universal key | | | | | | | | | |
| Digital pressure switch options | | | | | | | | | |
| A : Cable 150 mm + M8 PNP | | | | | | | | | |
| B : Cable 150 mm + M8 NPN | | | | | | | | | |
| C : Cable 2 m PNP | | | | | | | | | |
| D : Cable 2 m NPN | | | | | | | | | |

Example : T173BRMD : Size 3 regulator G1/2" 0 - 12 bar



Characteristic curves

2
AIR TREATMENT

Size 1 - G1/4" 0-8 bar P1=7 bar

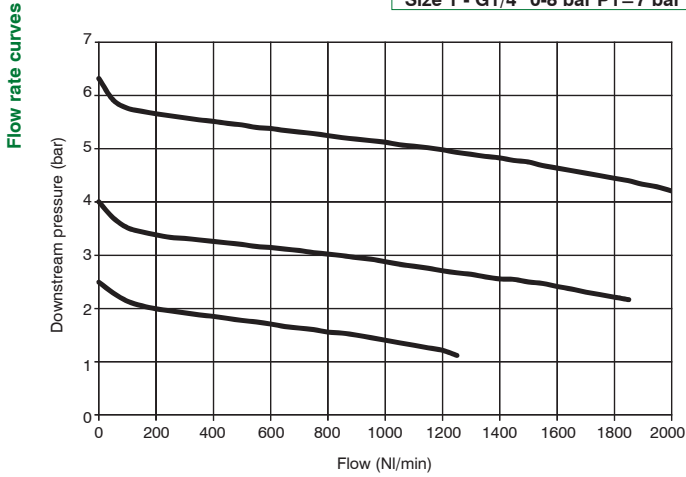

Adjustment characteristic

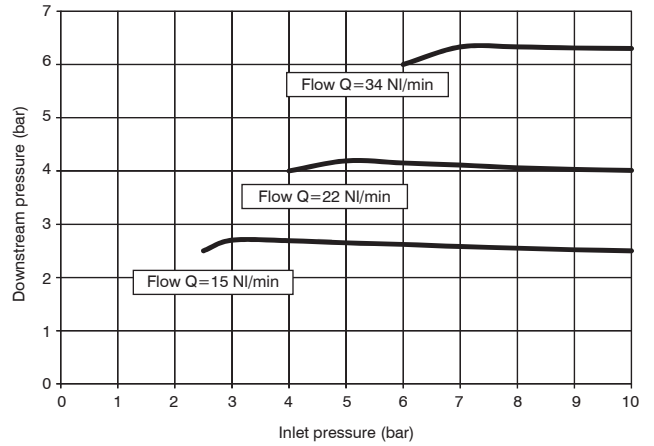

Size 2 - G3/8" 0-8 bar P1=7 bar

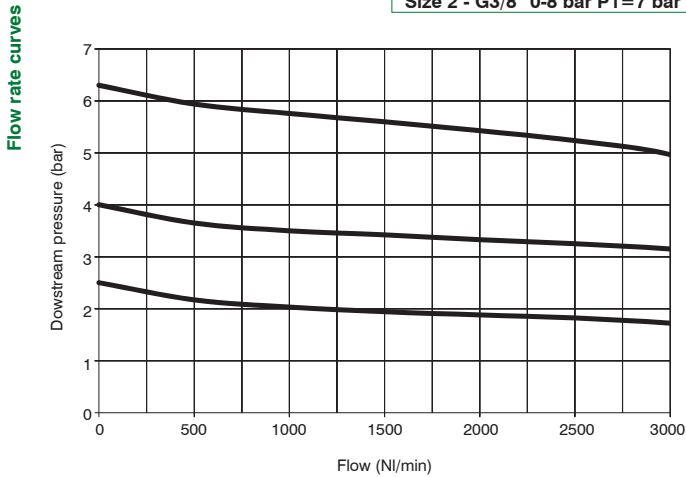

Adjustment characteristic

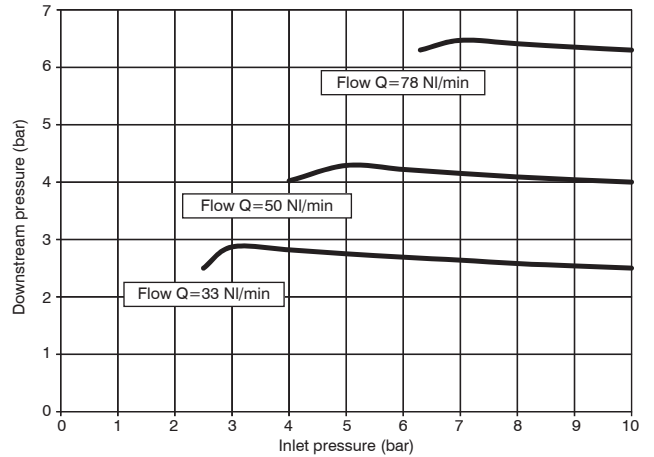

Size 3 - G1/2" 0-8 bar P1=7 bar

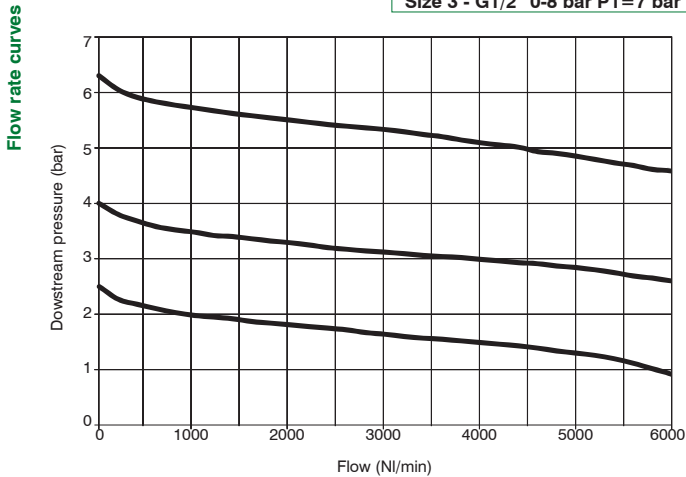

Adjustment characteristic

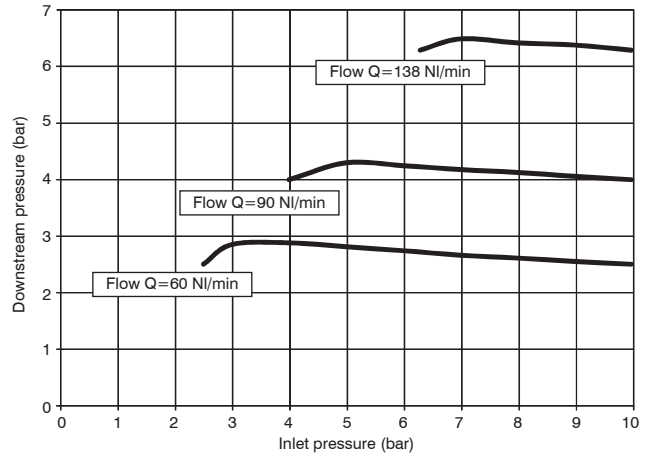

Size 4 - G1" 0-8 bar P1=10 bar

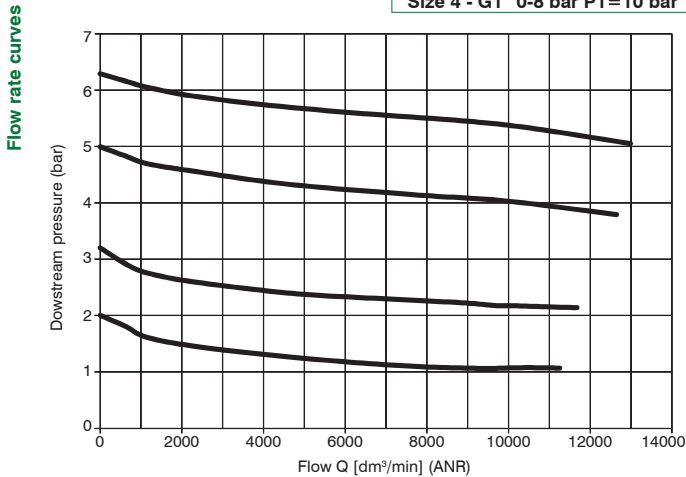

Adjustment characteristic

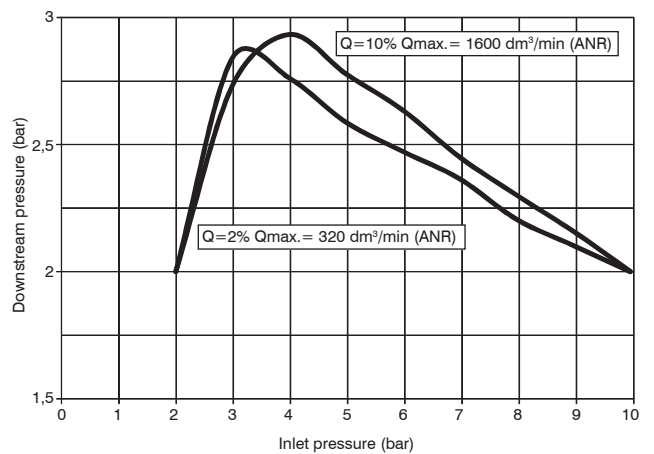

Dimensions

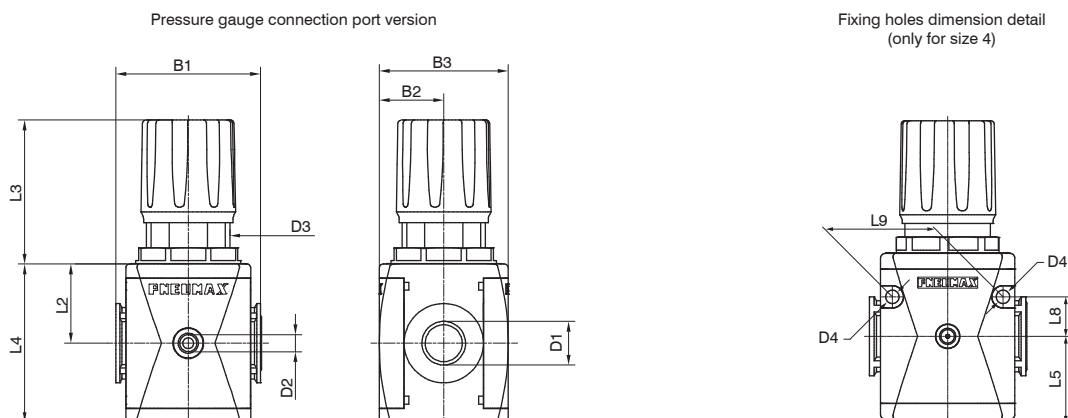

| Model | B1 | B2 | B3 | D1 | D2 | D3 | D4 | L2 | L3 | L4 | L5 | L8 | L9 |
|--------|----|------|----|--|-------------------|---------|-----|------|------|-----|------|----|----|
| #171.. | 48 | 21 | 42 | G1/8" G1/4" 1/4" NPT | G1/8" 1/8" NPT | M30x1,5 | / | 27,5 | 54 | 55 | / | / | / |
| #172.. | 62 | 28,5 | 57 | G1/4" G3/8" 1/4" NPT 3/8" NPT | G1/8" 1/8" NPT | M42x1,5 | / | 34 | 71,8 | 68 | / | / | / |
| #173.. | 73 | 32,5 | 65 | G3/8" G1/2" 1/2" NPT | G1/8" 1/8" NPT | M42x1,5 | / | 40 | 72,8 | 80 | / | / | / |
| #174.. | 99 | 44 | 88 | G1" 1" NPT | G1/8" 1/8" NPT | M54x1,5 | 8,5 | 52,5 | 87,5 | 105 | 54,5 | 25 | 70 |

AIR TREATMENT

2

Variable dimensions

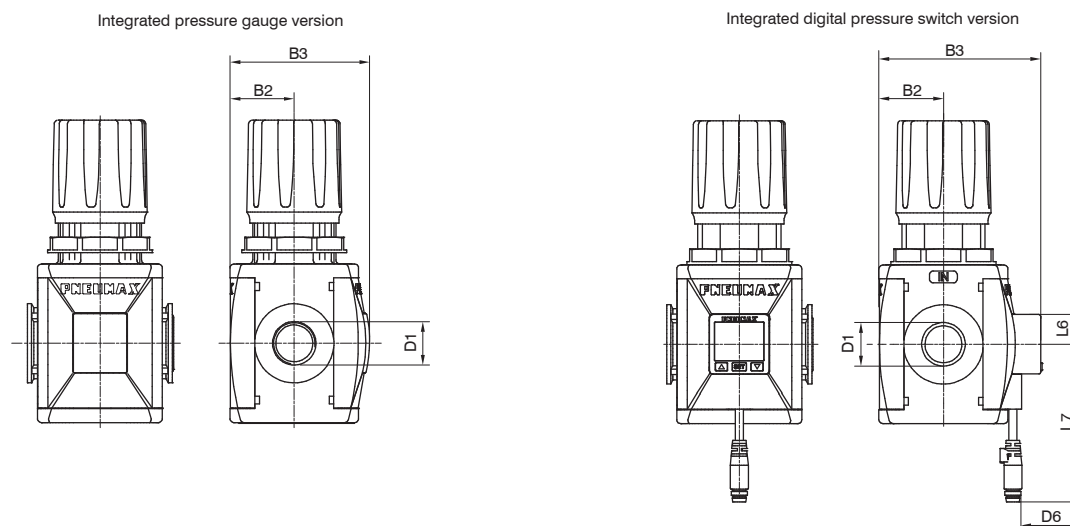

| Model | B2 | B3 | | D1 | D6 - Type of digital pressure switch | | L6 | L7 - Type of digital pressure switch | |
|--------|------|---------------------|------------------------------|--|--------------------------------------|------------------------|----|--------------------------------------|-------|
| | | With pressure gauge | With digital pressure switch | | A - B | C - D | | A - B | C - D |
| #171.. | 21 | 48,5 | 60 | G1/8" G1/4" 1/4" NPT | M8 - 3 PIN | 3 x 0,129 mm, Ø4 mm | 15 | 150 | 2000 |
| #172.. | 28,5 | 62,5 | 73,5 | G1/4" G3/8" 1/4" NPT 3/8" NPT | | | | | |
| #173.. | 32,5 | 70,5 | 81,5 | G3/8" G1/2" 1/2" NPT | | | | | |
| #174.. | 44 | 90,5 | 101,5 | G1" 1" NPT | | | | | |

► **Fixing bracket**

T172 50

| Size |
|------------------------|
| 171 : Size 1 |
| T172 : Size 2 - Size 3 |

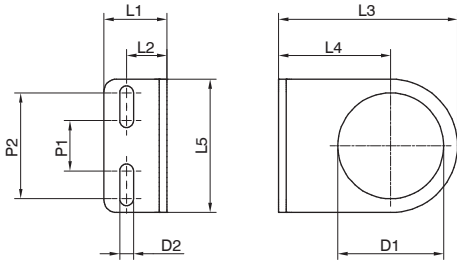

2

AIR TREATMENT

| Model | L1 | L2 | L3 | L4 | L5 | D1 | D2 | P1 | P2 |
|--------|----|----|----|------|----|----|-----|----|----|
| 17150 | 20 | 13 | 50 | 30 | 40 | 30 | 5,5 | 20 | 30 |
| T17250 | 25 | 16 | 71 | 44,5 | 53 | 42 | 5,5 | 20 | 42 |

► **Pressure gauge**

17070 A C

| Version |
|--------------|
| A : Dial Ø40 |
| B : Dial Ø50 |

| Scale |
|----------------|
| A : 0 - 4 bar |
| B : 0 - 6 bar |
| C : 0 - 12 bar |

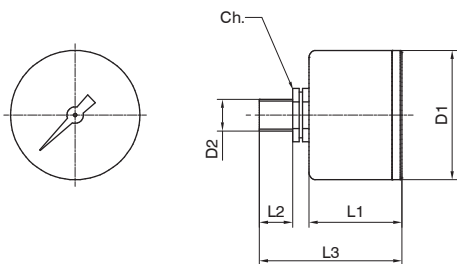

| Model | L1 | L2 | L3 | D1 | D2 | Ch |
|----------|----|----|----|----|-----------|----|
| 17070A.. | 26 | 10 | 44 | 41 | Gc - 1/8" | 14 |
| 17070B.. | 27 | 10 | 45 | 49 | Gc - 1/8" | 14 |

▶ **Piloted pressure regulators (RP - RMP - RPP)**



- ▶ Piston piloted pressure regulator
- ▶ Available with pressure gauge or digital pressure switch integrated
- ▶ Atex certification (II 2GD or II 3GD)
- ▶ Inlet pressures up to 20 bar

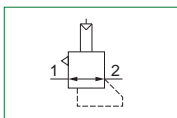

Note
Always regulate the rising pressure.

| Technical characteristics | |
|---|---|
| Size | Size 4 |
| Body and connections type | Aluminium body, integrated aluminium connections |
| IN / OUT connections | G1" - 1" NPT |
| Assembly configuration | Stand alone Panel mounted |
| Assembly positions | Indifferent |
| Pressure range | 0,5 - 10 bar |
| Regulation | Pneumatic piloting |
| Pressure measurement | G1/8" - 1/8" NPT pressure gauge connection port (only for versions with IN / OUT NPT connections) Integrated pressure gauge (optional) Digital pressure switch (optional) |
| Max. fittings torque IN / OUT connections | G1"metal: 35Nm |
| Max.fitting torque pressure gauge connection port | G1/8"metal: 15Nm |

| Operational characteristics | |
|--|--------------|
| Size | Size 4 |
| Maximum working pressure | 20 bar |
| Minimum working pressure | 0,5 bar |
| Pilot pressure range | 0,5 - 10 bar |
| Working temperature | -30°C +80°C |
| Working temperature with digital pressure switch | 0°C +50°C |

2
AIR TREATMENT



| Weights | | | | | |
|---------------------------------------|------|--------|--------|--------|--------|
| | Size | Size 1 | Size 2 | Size 3 | Size 4 |
| Pneumatic pilot aluminum body version | | / | / | / | 1190 g |

Materials

Exploded sectioned

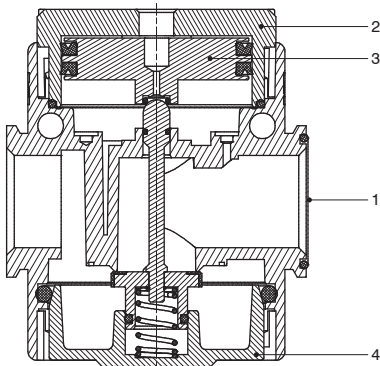

| Piloted pressure regulator | | |
|----------------------------|-------------------|--------------------|
| 1 | Body | Die-cast aluminium |
| 2 | Piloting operator | Aluminium |
| 3 | Piston | Aluminium |
| 4 | Rear end cap | Die-cast aluminium |

2

AIR TREATMENT

Design

G1/8" pressure gauge connection port version

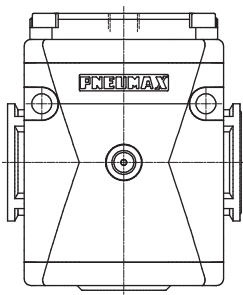

Integrated pressure gauge version

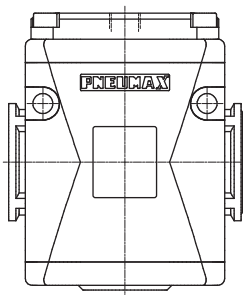

Integrated digital pressure switch version

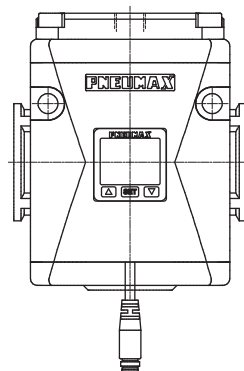

Order codes

P 17 4B R M P

| | |
|--|---|
| Version | P : Aluminium body |
| Size and connections | 4B : Size 4 - G1" 4C : Size 4 - 1" NPT |
| Pressure measurement options | : G1/8" - 1/8" NPT thread M : Integrated pressure gauge W : Integrated pressure gauge Right - Left P : Digital pressure switch Z : Digital pressure switch Right - Left |
| Digital pressure switch options | A : Cable 150 mm + M8 PNP B : Cable 150 mm + M8 NPN C : Cable 2 m PNP D : Cable 2 m NPN |

Example : P174BRMP : Size 4 piloted pressure regulator G1", integrated pressure gauge

Characteristic curves

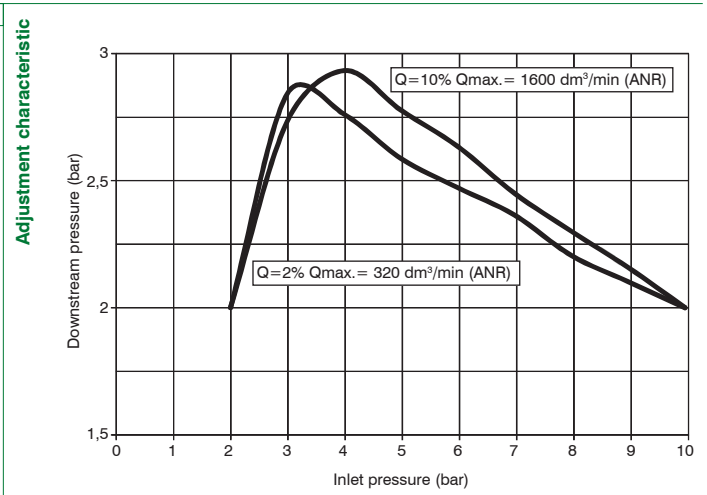
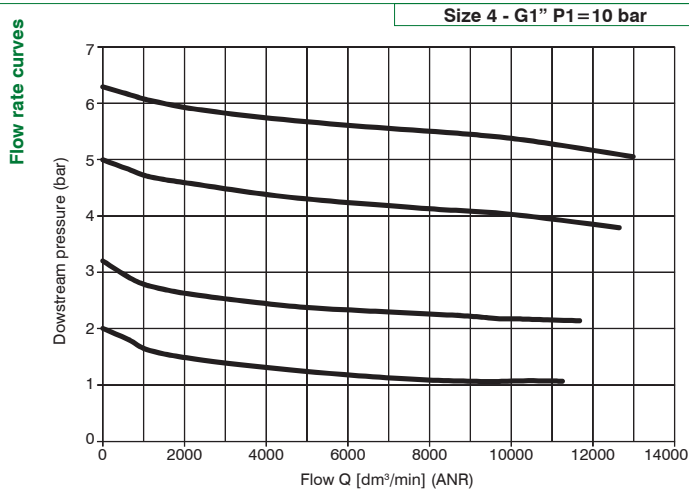

Piloting curves

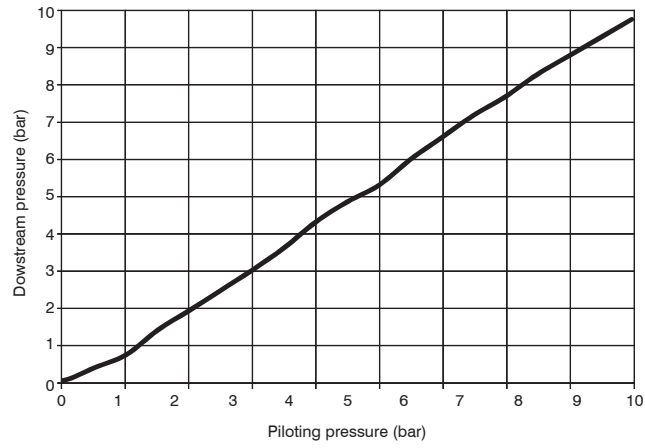



Dimensions

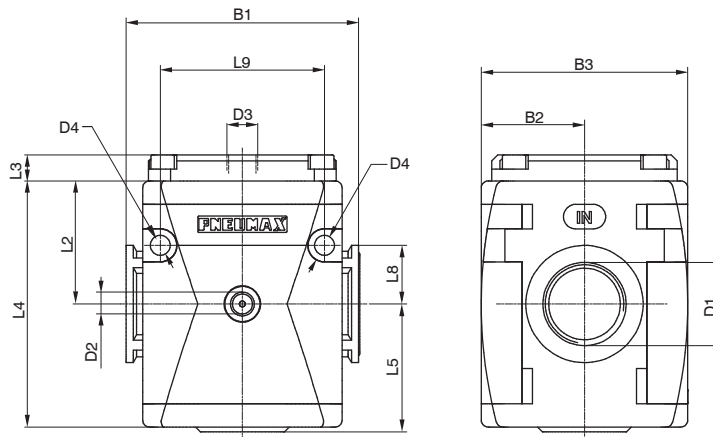

2 AIR TREATMENT

| Model | B1 | B2 | B3 | D1 | D2 | D3 | D4 | L2 | L3 | L4 | L5 | L8 | L9 |
|--------|----|----|----|------------|----------------|-------|-----|------|----|-----|------|----|----|
| #174.. | 99 | 44 | 88 | G1" 1" NPT | G1/8" 1/8" NPT | G1/4" | 8,5 | 52,5 | 11 | 105 | 54,5 | 25 | 70 |

Variable dimensions

Integrated pressure gauge version

Integrated digital pressure switch version

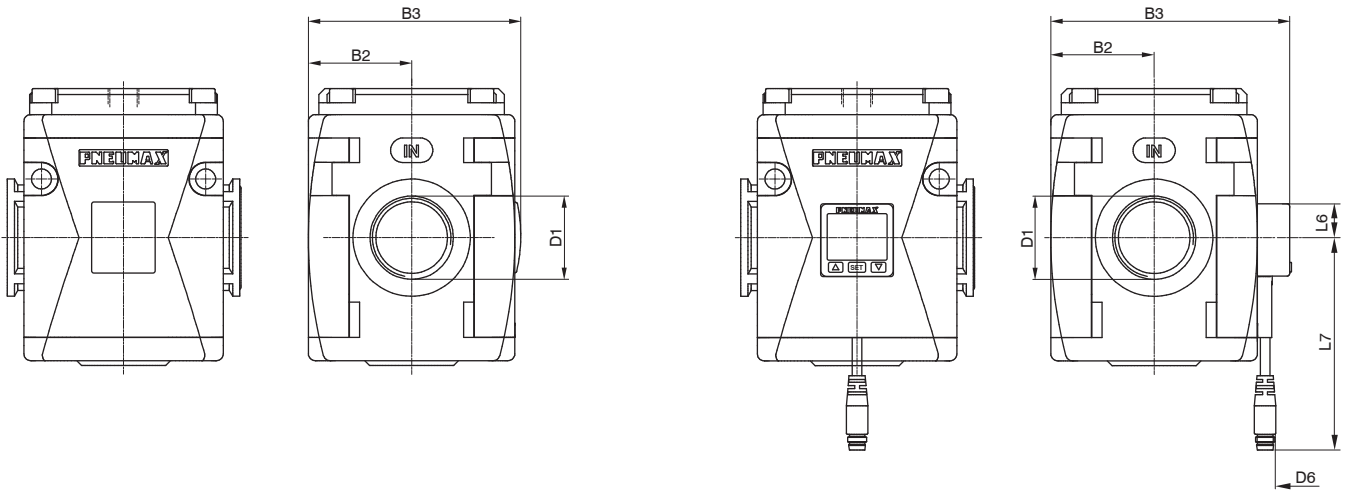

| Model | B2 | B3 | | D1 | D6 - Type of digital pressure switch | | L6 | L7 - Type of digital pressure switch | |
|--------|----|---------------------|------------------------------|------------|--------------------------------------|---------------------|----|--------------------------------------|-------|
| | | With pressure gauge | With digital pressure switch | | A - B | C - D | | A - B | C - D |
| #174.. | 44 | 90,5 | 101,5 | G1" 1" NPT | M8 - 3 PIN | 3 x 0,129 mm, Ø4 mm | 15 | 150 | 2000 |

Digital pressure switch



- ▶ 3 color digital LCD display, easy readout
- ▶ 4 units of measurement for pressure indication
- ▶ Optional PNP or NPN digital output
- ▶ N.O. and N.C. output contact selection directly on the digital pressure switch
- ▶ Available with M8-3PIN connector or 3 wire cable length 2 m
- ▶ Available only in combination with a regulator

Output circuit wiring diagrams

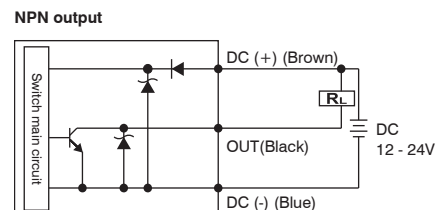
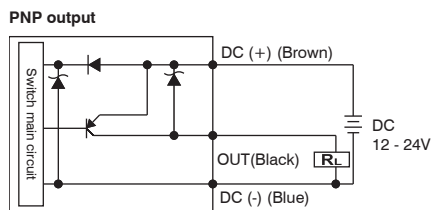

Digital pressure switch lay out

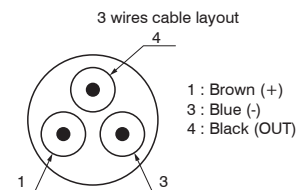
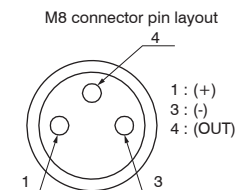

Cable ordering code

- MCH1** : cable 3 wires l=2,5m with M8 connector
- MCH2** : cable 3 wires l=5m with M8 connector
- MCH3** : cable 3 wires l=10m with M8 connector



| Technical characteristics | |
|--------------------------------|---|
| Pressure range and display | 0 - 10 bar |
| Max. inlet pressure | 15 bar |
| Fluid | 40µm filtered and dehumidified air |
| Display unit of measurement | MPa - kgf/cm² - bar - psi |
| Supply voltage | 12 - 24 VDC |
| Current consumption | ≤40mA (without load) |
| Digital output type | PNP - NPN |
| Type of contact output | Normally Open - Normally Closed |
| Max. load current | 125 mA |
| Digital output activation mode | single threshold with fixed hysteresis - window with fixed hysteresis - window without hysteresis |
| Digital output activation time | 0.05s - 0.25s - 0.5s - 1s - 2s - 3s (selections for chattering-proof options) |
| Display characteristics | Double 3 1/2 digit display Digital output status indication Three-pushbuttons touchpad |
| Indicator accuracy | ≤ ±2% full scale value ± 1 digit |
| IP Rating | IP40 |
| Working temperature | 0°C +50°C |
| Cable section | 3 x 0,129mm², Ø4 mm, PVC |

► Pressure regulators for manifold (B - M)



- ▶ Diaphragm pressure regulator with relieving
- ▶ Available with 2 front outputs connections G1/8 " or with 1 front output and integrated pressure gauge on the opposite side
- ▶ Low hysteresis rolling diaphragm and balanced spool
- ▶ Available in four pressure ranges up to 12 bar
- ▶ Fitted with panel mounting locking ring
- ▶ Available with Integrated pressure gauge
- ▶ Air supply can be applied by both directions (Right or Left)
- ▶ Max. 6off pressure regulators in manifold configuration
- ▶ Atex certification (II 3GD)

2

AIR TREATMENT

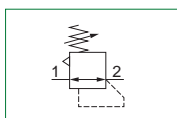

Note
For installations where a more accurate and constant pressure is required, the unit should be installed as close as possible to the point of use.

| Technical characteristics | |
|--|---|
| Size | Size 1 |
| Body and connections type | Technopolymer body, integrated technopolymer connections (T version) Technopolymer body, metal connections (N version) |
| IN connections | T version |
| | N version |
| OUT connections | |
| Assembly configuration | |
| Assembly positions | |
| Pressure range | |
| Regulation | |
| Pressure measurement | |
| Max. fittings torque IN / OUT connections | |
| Max.fitting torque pressure gauge connection port | |

| Operational characteristics | |
|---------------------------------|--------|
| Size | Size 1 |
| Maximum working pressure | |
| Minimum working pressure | |
| Working temperature | |

| Weights | | |
|----------------------------|------|--------|
| | Size | Size 1 |
| Technopolymer body version | | 140 g |

Materials

Exploded sectioned

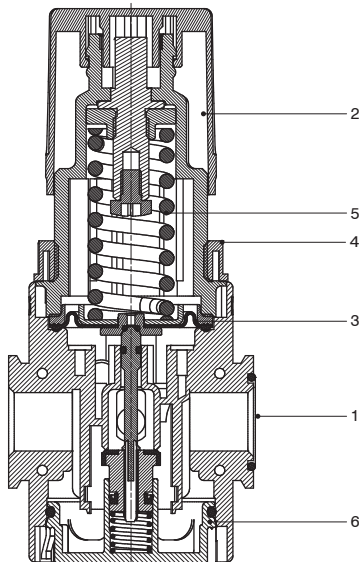

| Pressure regulator for manifold | | |
|---------------------------------|-----------------------------|---------------------------------|
| 1 | Body | Polyamide Die-cast aluminium |
| 2 | Adjusting knob | Polyamide |
| 3 | Diaphragm | NBR |
| 4 | Panel mounting locking ring | Polyamide |
| 5 | Adjusting spring | Steel |
| 6 | Rear end cap | Polyamide / Die-cast aluminium |

2

AIR TREATMENT

Design

Pressure gauge connection port version

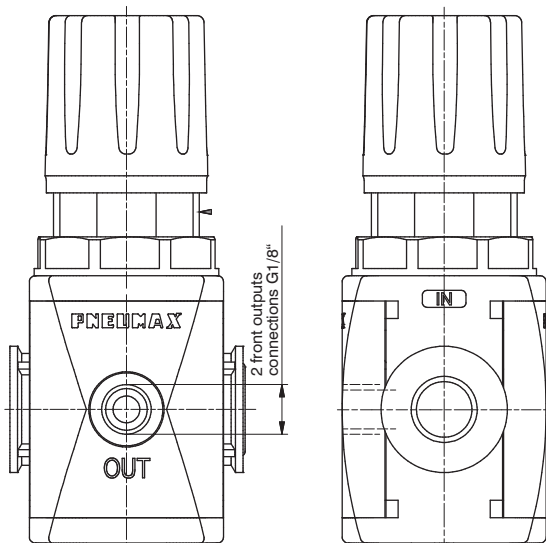

Integrated pressure gauge version

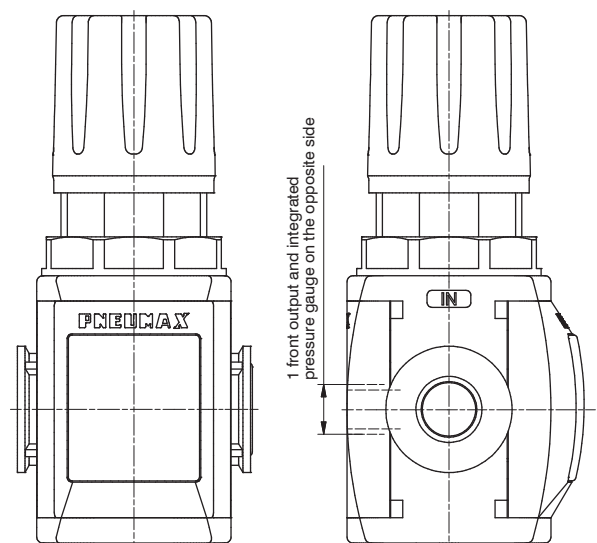



Order codes

T 17 1B B D

| Version | |
|---------|--|
| N | : Technopolymer body and metal inserts |
| T | : Technopolymer body and thread |

| Size and connections | |
|----------------------|--|
| 1A | : Size 1 - G1/8" |
| 1B | : Size 1 - G1/4" |
| 1C | : Size 1 - 1/4" NPT only for N version |

| Pressure measurement options | |
|------------------------------|-----------------------------|
| B | : G1/8" - 1/8" NPT thread |
| M | : Integrated pressure gauge |

| Pressure range | |
|----------------|--------------|
| A | : 0 - 2 bar |
| B | : 0 - 4 bar |
| C | : 0 - 8 bar |
| D | : 0 - 12 bar |

| Relieving options | |
|-------------------|--|
| | : With relieving |
| F | : Controlled refuel and improved relieving |
| L | : Without relieving |
| R | : Improved relieving |

| Knob options | |
|--------------|---------------------------------------|
| | : Non-lockable version |
| K | : Lockable version |
| U | : Lockable version with universal key |

Example : T171BBD : Size 1 pressure regulator for manifold G1/4", 0 - 12 bar

Characteristic curves

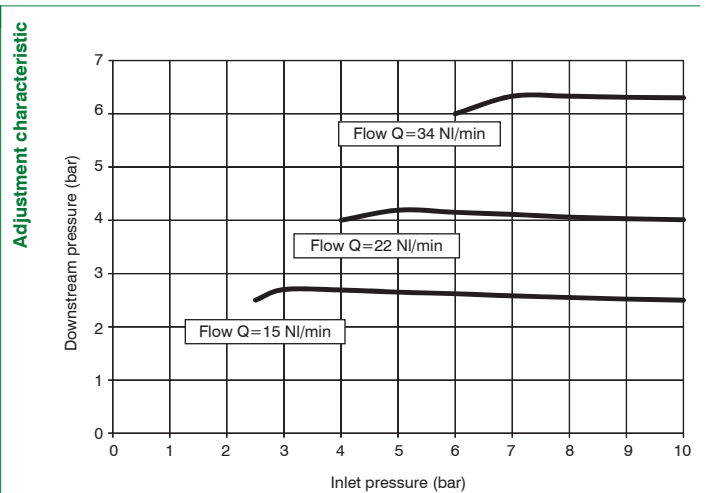
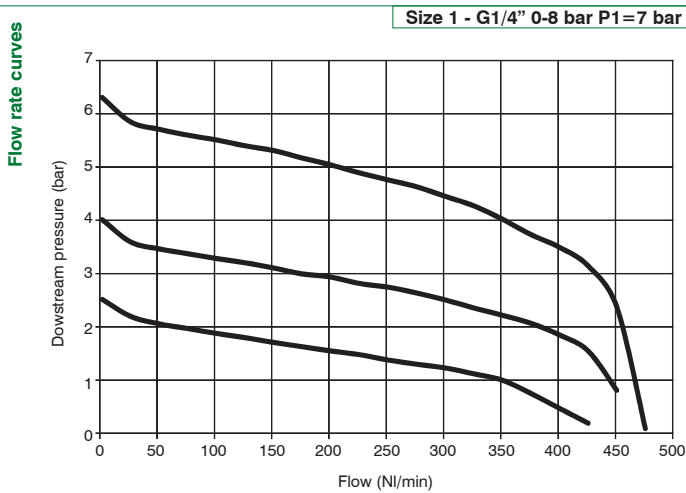

2 AIR TREATMENT

Dimensions

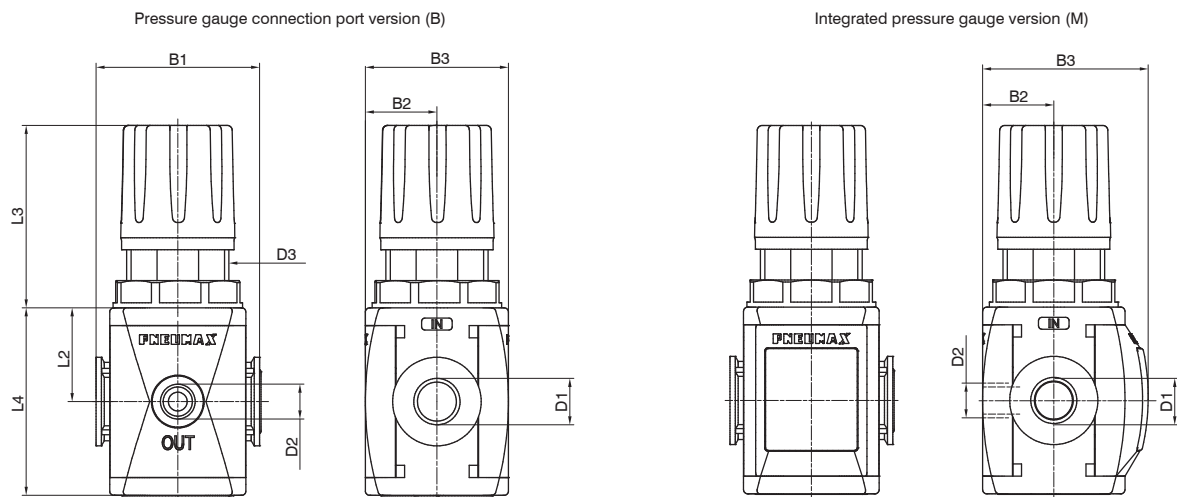

| Model | B1 | B2 | B3 | | D1 | D2 | D3 | L2 | L3 | L4 |
|--------|----|----|-----------|-----------|----------------------------|-------|---------|------|----|----|
| | | | B version | M version | | | | | | |
| #171.. | 48 | 24 | 42 | 48,5 | G1/4" G1/8" 1/4" NPT | G1/8" | M30x1,5 | 27,5 | 54 | 55 |

▶ **Manifold pressure regulators**



- ▶ Manifold pressure regulators
- ▶ Available in four pressure ranges up to 12 bar
- ▶ Inlet pressure common for the whole manifold of pressure regulator
- ▶ A maximum of 6 pressure regulators can be mounted
- ▶ Atex certification (II 3GD)
- ▶ Assembly with X or Y flanges

2

AIR TREATMENT

| Technical characteristics | | Size | Size 1 |
|--|-----------|---|--------|
| Body and connections type | | Technopolymer body, integrated technopolymer connections (T version) Technopolymer body, metal connections (N version) | |
| IN connections | T version | G1/4" | |
| | N version | G1/8" - G1/4" - 1/4" NPT | |
| OUT connections | | G1/8" | |
| Assembly configuration | | Stand alone Panel mounting With fixing bracket | |
| Assembly positions | | Indifferent | |
| Pressure range | | 0-2 bar 0-4 bar 0-8 bar 0-12 bar | |
| Regulation | | Manul push and lock with pressure Manual lockable with accessories | |
| Pressure measurement | | G1/8" pressure gauge connection port Integrated pressure gauge (optional) | |
| Max. fittings torque IN / OUT connections | | G1/8" metal: 15Nm G1/4" metal: 20Nm G1/4" technopolymer: 9Nm | |
| Max.fitting torque pressure gauge connection port | | G1/8" technopolymer: 4Nm G1/8" metal: 15Nm | |

| Operational characteristics | | Size | Size 1 |
|---------------------------------|--|------------|--------|
| Maximum working pressure | | 13 bar | |
| Minimum working pressure | | 0,5 bar | |
| Working temperature | | -5°C +50°C | |



Order codes

G T 17 1B M 6 C C C C C C

| |
|--|
| Version |
| N : Technopolymer body and metal inserts |
| T : Technopolymer body and thread |

| |
|---|
| Size and connections |
| 1A : Size 1 - G1/8" |
| 1B : Size 1 - G1/4" |
| 1C : Size 1 - 1/4" NPT only for N version |

| |
|---|
| Pressure measurement options |
| B : G1/8" thread with flanges X |
| M : Integrated pressure gauge with flanges X |
| P : G1/8" thread with extended flanges Y |
| R : Integrated pressure gauge with extended flanges Y |
| W : G1/8" thread with flanges Y |
| Z : Integrated pressure gauge with flanges Y |

| |
|-----------------------------|
| Number of regulators |
| 2 : n. 2 regulators |
| 3 : n. 3 regulators |
| 4 : n. 4 regulators |
| 5 : n. 5 regulators |
| 6 : n. 6 regulators |

| |
|-----------------------|
| Pressure range |
| A : 0 - 2 bar |
| B : 0 - 4 bar |
| C : 0 - 8 bar |
| D : 0 - 12 bar |

| |
|-----------------------|
| Pressure range |
| A : 0 - 2 bar |
| B : 0 - 4 bar |
| C : 0 - 8 bar |
| D : 0 - 12 bar |

| |
|-----------------------|
| Pressure range |
| A : 0 - 2 bar |
| B : 0 - 4 bar |
| C : 0 - 8 bar |
| D : 0 - 12 bar |

| |
|-----------------------|
| Pressure range |
| A : 0 - 2 bar |
| B : 0 - 4 bar |
| C : 0 - 8 bar |
| D : 0 - 12 bar |

| |
|-----------------------|
| Pressure range |
| A : 0 - 2 bar |
| B : 0 - 4 bar |
| C : 0 - 8 bar |
| D : 0 - 12 bar |

| |
|-----------------------|
| Pressure range |
| A : 0 - 2 bar |
| B : 0 - 4 bar |
| C : 0 - 8 bar |
| D : 0 - 12 bar |

Example : T171BM6CCCCC : Size 1 manifold pressure regulators G1/4", 0 - 8 bar, integrated pressure gauge

Dimensions

2
AIR TREATMENT

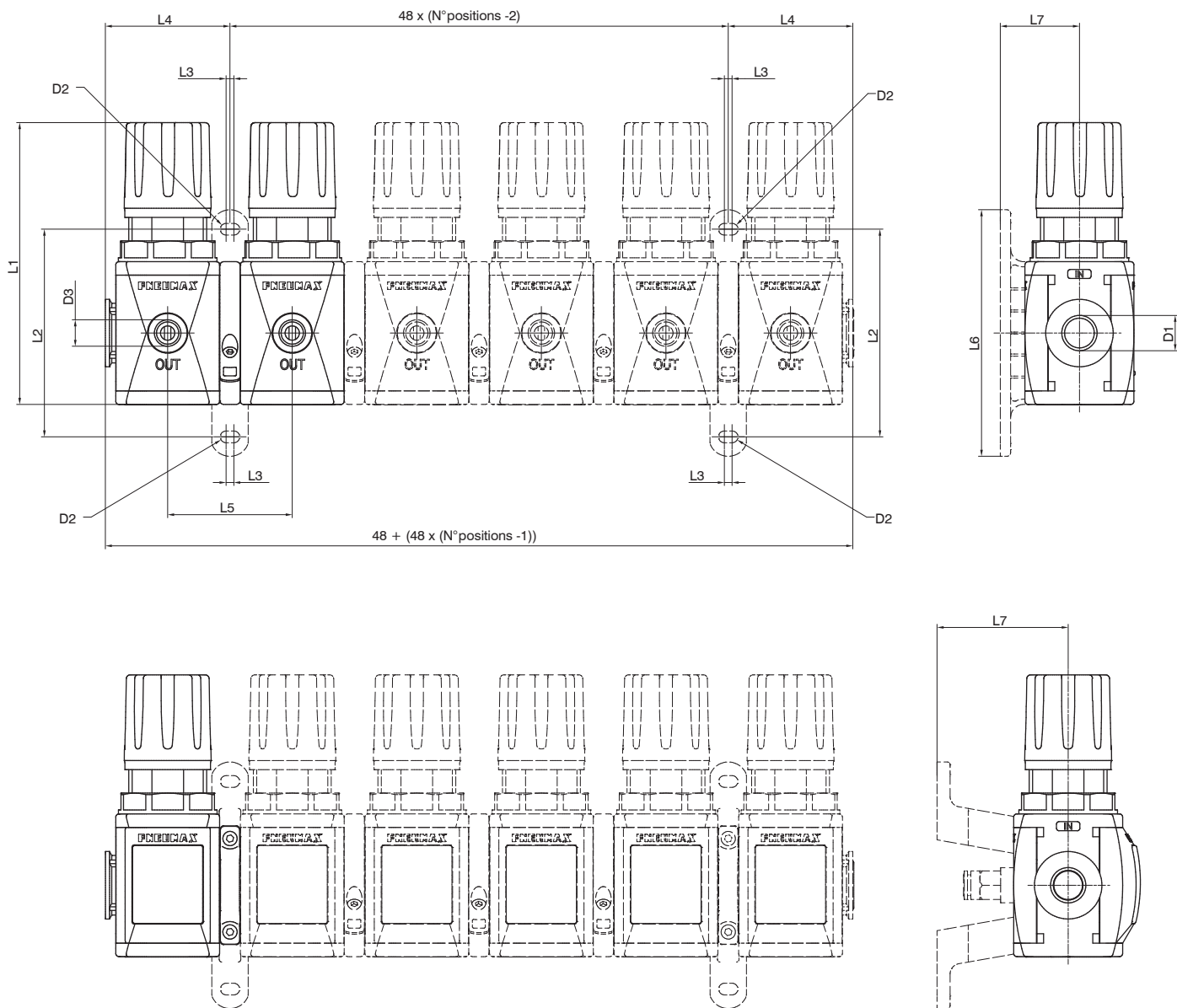

| Model | D1 | D2 | D3 | L1 | L2 | L3 | L4 | L5 | L6 | L7 |
|-------------------------------|----------------------------|------|-------|-----|------|----|----|----|-----|------|
| #171..with flanges X | G1/4" G1/8" 1/4" NPT | / | G1/8" | 109 | / | / | 48 | 48 | / | / |
| #171..with flanges Y | | Ø4,5 | | | 80 | 3 | | | 105 | 30,5 |
| #171..with extended flanges Y | | | | | 50,5 | | | | | |

► Manifold mounting flanges

Flange Y

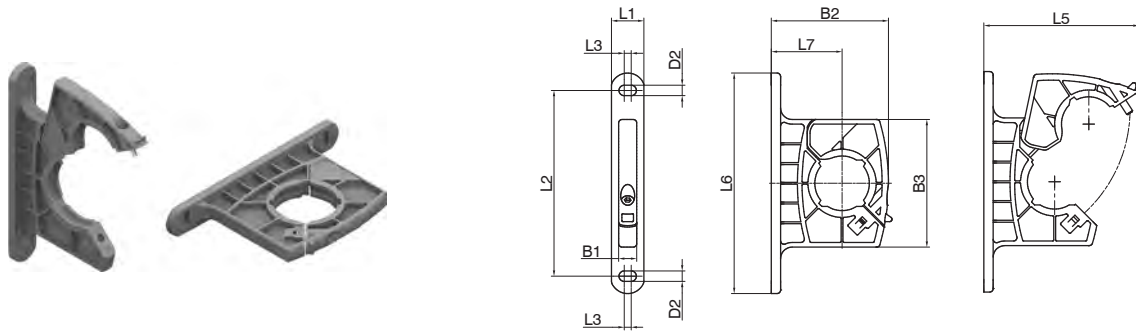

Extended flange Y

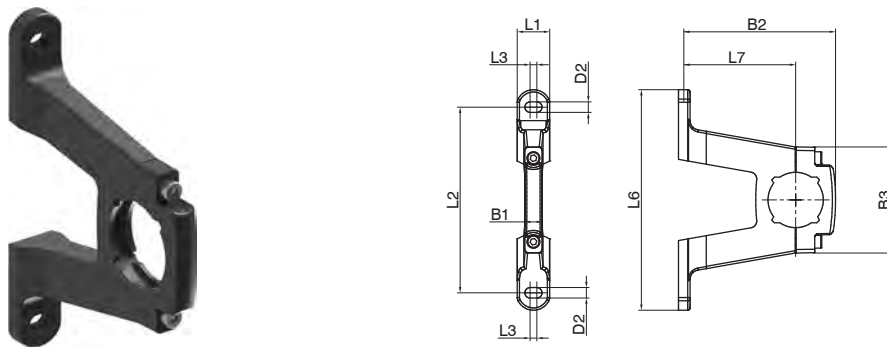

Flange X

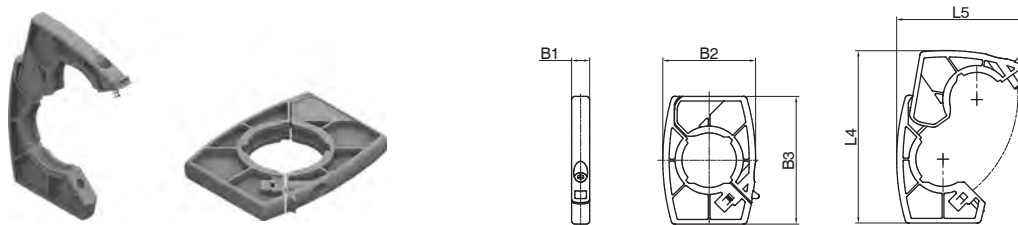

| Model | B1 | B2 | B3 | D2 | L1 | L2 | L3 | L4 | L5 | L6 | L7 |
|--------|-----|------|------|------|----|----|----|------|------|----|------|
| T171Y | 7,8 | 50,5 | 55 | Ø4,5 | 14 | 80 | 3 | / | 66 | 95 | 30,5 |
| N171YP | | 67,7 | 45,7 | Ø4,5 | 14 | 80 | 3 | / | 66 | | 50,5 |
| T171X | | 40 | 55 | / | / | / | / | 74,5 | 55,5 | / | / |

► **Fixing bracket**

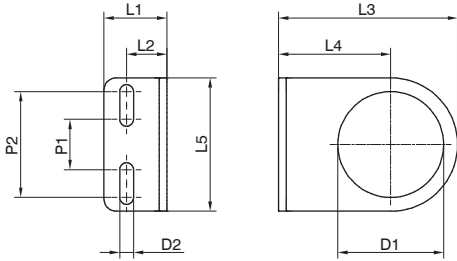

2
AIR TREATMENT

| Model | L1 | L2 | L3 | L4 | L5 | D1 | D2 | P1 | P2 |
|-------|----|----|----|----|----|----|-----|----|----|
| 17150 | 20 | 13 | 50 | 30 | 40 | 30 | 5,5 | 20 | 30 |

► **Pressure gauge**

17070 **A** **C**

| Version |
|--------------|
| A : Dial Ø40 |
| B : Dial Ø50 |

| Scale |
|----------------|
| A : 0 - 4 bar |
| B : 0 - 6 bar |
| C : 0 - 12 bar |

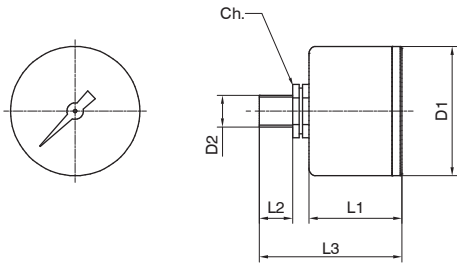

| Model | L1 | L2 | L3 | D1 | D2 | Ch |
|----------|----|----|----|----|-----------|----|
| 17070A.. | 26 | 10 | 44 | 41 | Gc - 1/8" | 14 |
| 17070B.. | 27 | 10 | 45 | 49 | Gc - 1/8" | 14 |



Lubricators (L)



- ▶ Oil mist lubricator
- ▶ Available in 4 sizes with flow rates up to 16000 NI/min and connections from 1/8" to 1"
- ▶ Bowl assembly via bayonet type quick coupling mechanism with safety button
- ▶ Variable orifice size in function of the flow rate
- ▶ Oil quantity regulation mechanism and oil quantity visualization dome made of polycarbonate (PC)
- ▶ Oil refill plug
- ▶ Lubricator oil recharge with pressurized system
- ▶ Available with low level electrical sensor NO and NC
- ▶ Atex certification (II 2GD or II 3GD)

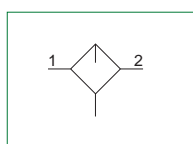

2

AIR TREATMENT

| Technical characteristics | | Size | Size 1 | Size 2 | Size 3 | Size 4 |
|--|------------------|---|--------|---|---|-----------------|
| Body and connections type | | Technopolymer body, integrated technopolymer connections (T version) Technopolymer body, metal connections (N version) | | | | / |
| | | / | | Aluminium body, integrated aluminium connections (P version) | | |
| Protection and bowl type | | Technopolymer protection - PC bowl Technopolymer protection - PA bowl | | | Metal protection - PC bowl Metal protection - PA bowl | |
| IN / OUT connections | T version | G1/4" | | G3/8" | G1/2" | non disponibile |
| | N version | G1/8" - G1/4" - 1/4" NPT | | G3/8" - G1/4" - 3/8" NPT | G3/8" - G1/2" - 1/2" NPT | |
| | P version | not available | | G3/8" | G1/2" | G1" |
| Assembly configuration | | Stand alone / | | | | Panel mounted |
| Assembly positions | | Vertical ±5° | | | | |
| Bowl capacity | | 36 cm³ | | 70 cm³ | 136 cm³ | 360 cm³ |
| Lubrication type | | Oil mist lubrication | | | | |
| Oil level regulation | | Manual, complete with visual indicator | | | | |
| Max. fittings torque IN / OUT connections | | G1/8" metal: 15Nm G1/4" metal: 20Nm G1/4" technopolymer: 9Nm | | G1/4" metal: 20Nm G3/8" metal: 25Nm G3/8" technopolymer: 16Nm | G3/8" metal: 25Nm G1/2" metal: 30Nm G1/2" technopolymer: 22Nm | G1" metal: 35Nm |

| Operational characteristics | | Size | Size 1 | Size 2 | Size 3 | Size 4 |
|---|--|------------------------------|--------|-----------|------------|------------|
| Maximum working pressure | | 13 bar | | | | |
| Minimum working pressure | | 0,5 bar | | | | |
| Min. operational flow at 6,3 bar | | 40 NI/min | | 70 NI/min | 100 NI/min | 100 NI/min |
| Indicative oil drop rate | | 1 drope every 300/600 NI/min | | | | |
| Oil type | | FD22 - HG32 | | | | |
| Working temperature | | -5°C +50°C | | | | |

| Weights | | | | |
|--|--------|--------|--------|--------|
| Size | Size 1 | Size 2 | Size 3 | Size 4 |
| Fully technopolymer version | 121 g | 215 g | 347 g | / |
| Technopolymer body version, aluminium bowl protection and technopolymer bowl | / | 245 g | 383 g | / |
| Aluminium body version, technopolymer protection and bowl | / | 315 g | 477 g | 1032 g |
| Aluminium body version, aluminium bowl protection and technopolymer bowl | / | 345 g | 513 g | 1077 g |

Materials

Exploded sectioned

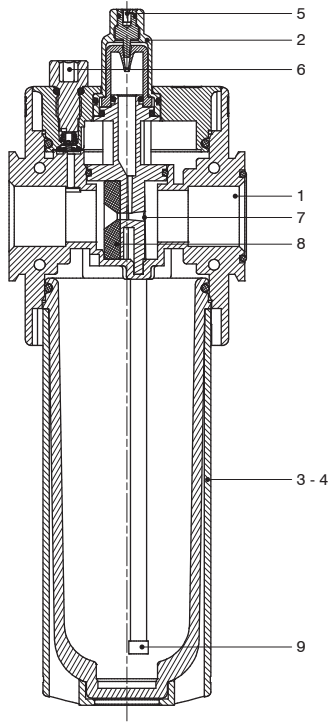

| Lubricator | | |
|------------|-----------------------|---------------------------------|
| 1 | Body | Polyamide Die-cast aluminium |
| 2 | Visual indicator | Polyamide |
| 3 | Technopolymer bowl | Polycarbonate Polyamide |
| 4 | Bowl protection | Polyamide - Die-cast aluminium |
| 5 | Oil regulation needle | Brass |
| 6 | Recharge plug | Acetal resin |
| 7 | Diaphragm support | Acetal resin |
| 8 | Diaphragm | NBR |
| 9 | Filter | Sintered brass |

2
AIR TREATMENT

Design

Size 1 - Size 2 - Size 3
Technopolymer protection

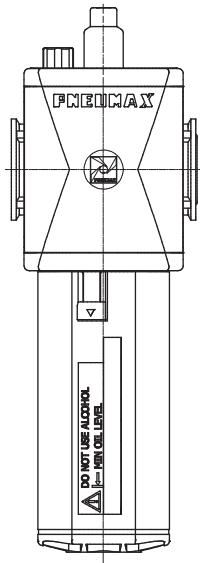

Size 1 - Size 2 - Size 3
Metal protection

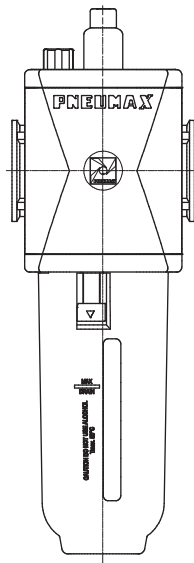

Size 4
All versions

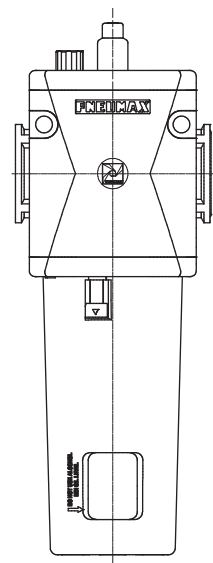



Order codes

| | | | | | | |
|--|----------|----|-----------|---|----------|----------|
| | T | 17 | 3B | L | A | N |
| Version | | | | | | |
| N : Technopolymer body and metal inserts (not available for size 4) | | | | | | |
| T : Technopolymer body and thread (not available for size 4) | | | | | | |
| P : Aluminium body (not available for size 1) | | | | | | |
| Size and connections | | | | | | |
| 1A : Size 1 - G1/8" only for N version | | | | | | |
| 1B : Size 1 - G1/4" only for T - N versions | | | | | | |
| 1C : Size 1 - 1/4" NPT only for N version | | | | | | |
| 2A : Size 2 - G1/4" only for N version | | | | | | |
| 2B : Size 2 - G3/8" for all versions | | | | | | |
| 2C : Size 2 - 3/8" NPT only for N version | | | | | | |
| 3A : Size 3 - G3/8" only for N version | | | | | | |
| 3B : Size 3 - G1/2" for all versions | | | | | | |
| 3C : Size 3 - 1/2" NPT only for N version | | | | | | |
| 4B : Size 4 - G1" only for P version | | | | | | |
| Options | | | | | | |
| : No electric level sensor device | | | | | | |
| A : Electrical minimum level sensor NO (not available for size 1) | | | | | | |
| C : Electrical minimum level sensor NC (not available for size 1) | | | | | | |
| Bowl options | | | | | | |
| : Technopolymer protection - PC bowl | | | | | | |
| N : Technopolymer protection - PA bowl | | | | | | |
| P : Metal protection - PC bowl (not available for size 1) | | | | | | |
| R : Metal protection - PA bowl (not available for size 1) | | | | | | |

Example : T173BLAN : Size 3 lubricator G1/2", normally open low level electrical sensor, PA bowl with technopolymer protection

Characteristic curves

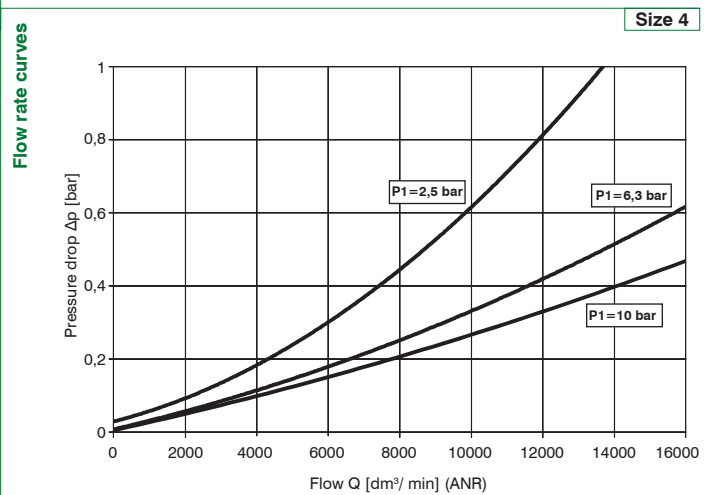
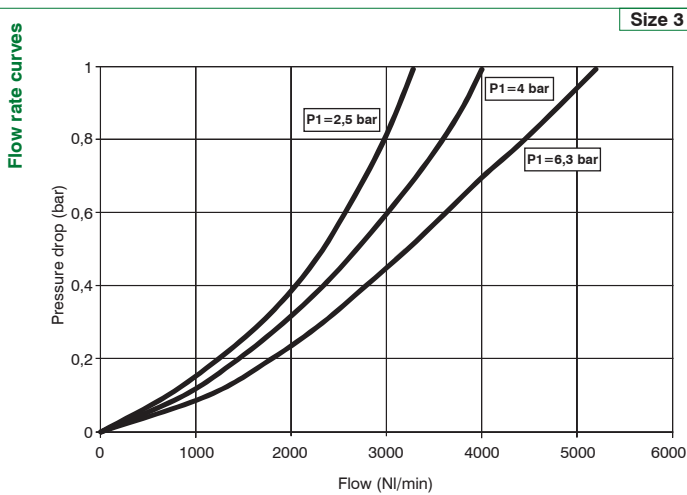
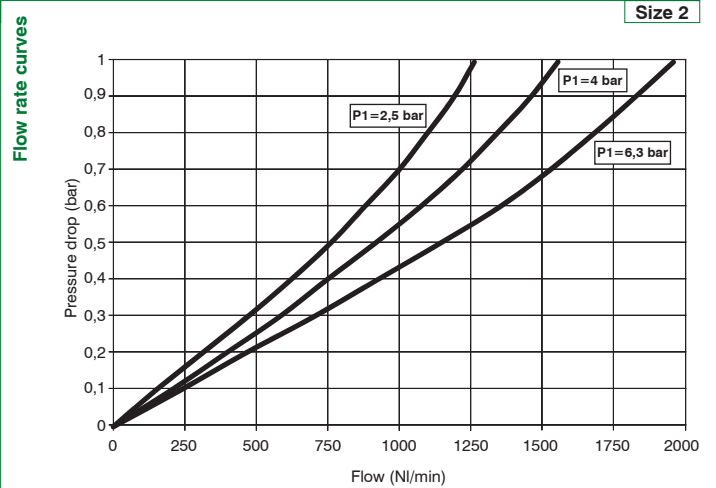
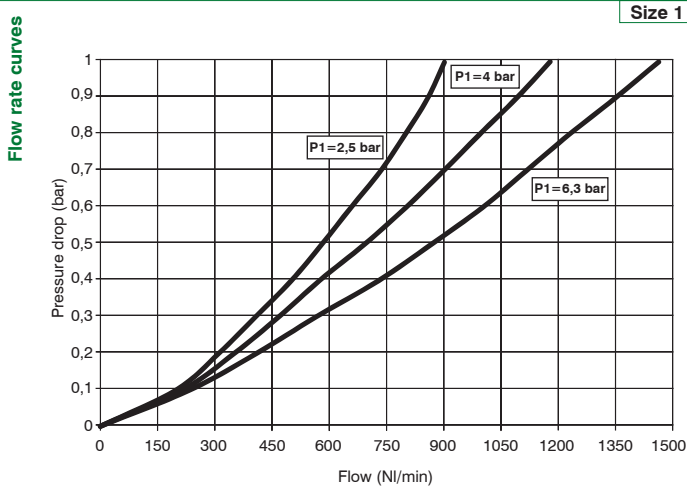

Dimensions

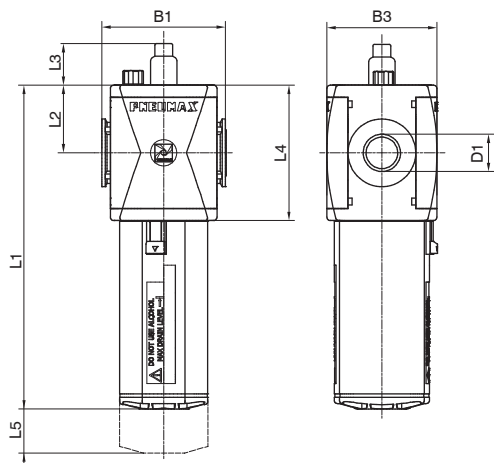

Fixing holes dimension detail (only for size 4)

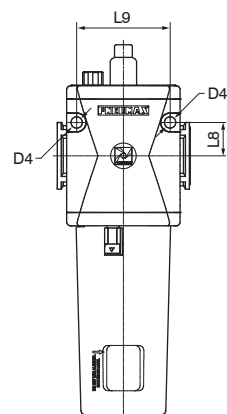

| Model | B1 | B3 | D1 | D4 | L1 | L2 | L3 | L4 | L5 | L8 | L9 |
|--------|----|----|----------------------------|-----|-------|------|----|-----|-----|----|----|
| #171.. | 48 | 42 | G1/8" G1/4" 1/4" NPT | / | 131 | 27,5 | 24 | 55 | 80 | / | / |
| #172.. | 62 | 57 | G1/4" G3/8" 3/8" NPT | / | 152.7 | 34 | 24 | 68 | 90 | / | / |
| #173.. | 73 | 65 | G3/8" G1/2" 1/2" NPT | / | 191.4 | 40 | 24 | 80 | 120 | / | / |
| #174.. | 99 | 88 | G1" | 8,5 | 247 | 52,5 | 24 | 105 | 145 | 25 | 70 |

Variable dimensions

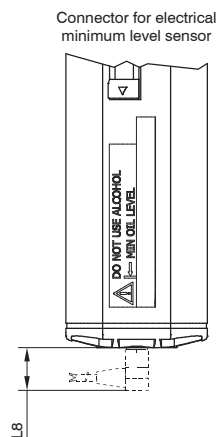

| Model | L8 | Connectors for electrical connection |
|------------------------------------|----|---|
| Electrical minimum level sensor NO | 16 | C1 - C2 - C3 (see sensors section of general catalog) |
| Electrical minimum level sensor NC | | |

Accessories

Electrical connection details

C1 : connector with 2,5 m cable 2 wires (PVC Ø3,5 mm 2x0,25mm²)

C2 : connector with 5 m cable 2 wires (PVC Ø3,5 mm 2x0,25mm²)

C3 : connector with 10 m cable 2 wires (PVC Ø3,5 mm 2x0,25mm²)

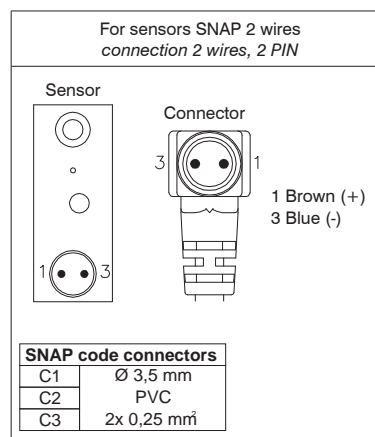

Shut off valves (VL - VP - VE)

- ▶ 3/2 N.C. shut off valve
- ▶ Suitable for system downstream pneumatic feeding or exhaust
- ▶ Manual, pneumatic and electropneumatic operation available
- ▶ Up to 3off manual operation lockable device available (closed position)
- ▶ Atex certification (II 2GD or II 3GD)

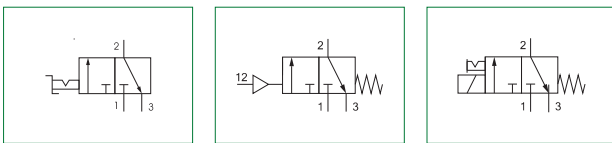
AIR TREATMENT
2

| Technical characteristics | | | | | |
|--|------------------------|---|---|---|--------------------------------------|
| Size | | Size 1 | Size 2 | Size 3 | Size 4 |
| Body and connections type | | Technopolymer body, integrated technopolymer connections (T version) Technopolymer body, metal connections (N version) | | | / |
| | | / | Aluminium body, integrated aluminium connections (P version) | | / |
| Operated type | | Manual Pneumatic Electropneumatic | | | |
| IN / OUT connections | T version | G1/4" | G3/8" | G1/2" | not available |
| | N version | G1/8" - G1/4" - 1/4" NPT | G3/8" - G1/4" - 3/8" NPT | G3/8" - G1/2" - 1/2" NPT | |
| | P and L version | not available | G3/8" | G1/2" | |
| Pilot connection | | G1/8" | | | |
| Exhaust connection | | G1/4" | G3/8" | G1/2" | |
| Assembly configuration | | Stand alone / | | | Panel mounted |
| Assembly positions | | Indifferent | | | |
| Max. fittings torque IN / OUT connections | | G1/8" metal: 15Nm G1/4" metal: 20Nm G1/4" technopolymer: 9Nm | G1/4" metal: 20Nm G3/8" metal: 25Nm G3/8" technopolymer: 16Nm | G3/8" metal: 25Nm G1/2" metal: 30Nm G1/2" technopolymer: 22Nm | G1/2" metal: 30Nm G1" metal: 35Nm |

| Operational characteristics | | | | | | | | |
|---|--|-------------|-------------|--------------|--|-------------|-------------|--------------|
| Size | Size 1 | Size 2 | Size 3 | Size 4 | Size 1 | Size 2 | Size 3 | Size 4 |
| Operator | Manual | | | | Pneumatic / Solenoid | | | |
| Maximum working pressure | 13 bar | | | 10 bar | 10 bar | | | |
| Minimum working pressure | 0,5 bar | | | | 2,5 bar | | | |
| Working temperature | -5°C +50°C | | | | -5°C +50°C | | | |
| | -30°C +80°C (only for P version) -40°C +80°C (only for L version) | | | | -30°C +80°C (only with metal body and pneumatic version) -40°C +80°C (only with metal body and pneumatic version) | | | |
| Nominal flow rate at 6 bar with Δp=1 (from 1 to 2) | 1400 NI/min | 2200 NI/min | 3600 NI/min | 15000 NI/min | 1400 NI/min | 2200 NI/min | 3600 NI/min | 15000 NI/min |
| Exhaust nominal flow rate at 6 bar with Δp=1 (from 2 to 3) | 550 NI/min | 1500 NI/min | | 3600 NI/min | 550 NI/min | 1500 NI/min | | 3600 NI/min |
| Un-conveyed exhaust nominal flow rate (from 2 to 3) | 1000 NI/min | 2500 NI/min | | 5000 NI/min | 1000 NI/min | 2500 NI/min | | 5000 NI/min |

| Weights | | | | | | | | |
|----------------------------|--------|-----------|----------------------|--------------------|--------|-----------|----------------------|--------------------|
| Size Operator | Size 1 | | | | Size 2 | | | |
| | Manual | Pneumatic | Solenoid M2 actuator | Solenoid 15mm coil | Manual | Pneumatic | Solenoid M2 actuator | Solenoid 15mm coil |
| Technopolymer body version | 110 g | 99 g | 140 g | 140 g | 190 g | 181 g | 210 g | 216 g |
| Aluminium body version | / | / | / | / | 270 g | 265 g | 298 g | 301 g |

| Size Operator | Size 3 | | | | Size 4 | | | |
|----------------------------|--------|-----------|----------------------|--------------------|--------|-----------|----------------------|--------------------|
| | Manual | Pneumatic | Solenoid M2 actuator | Solenoid 15mm coil | Manual | Pneumatic | Solenoid M2 actuator | Solenoid 15mm coil |
| Technopolymer body version | 250 g | 270 g | 310 g | 310 g | / | / | / | / |
| Aluminium body version | 400 g | 398 g | 429 g | 432 g | 1100 g | 1135 g | 1170 g | 1180 g |

Materials

Exploded sectioned

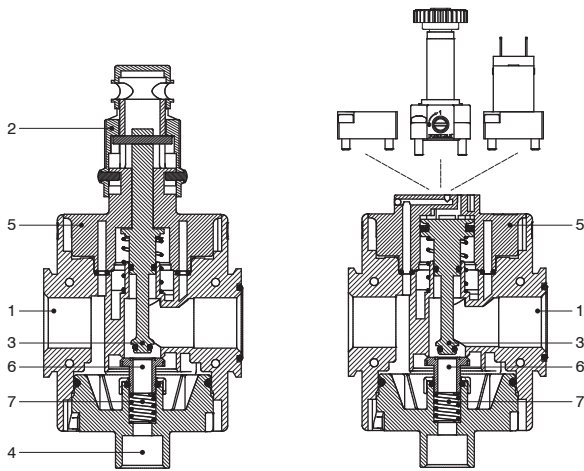

| Shut off valve | | |
|----------------|----------------------|---------------------------------|
| 1 | Body | Polyamide Die-cast aluminium |
| 2 | Manual override | Polyamide |
| 3 | Drive pin Piston | Aluminium |
| 4 | Exhaust plug | Polyamide |
| 5 | Central support | Polyamide |
| 6 | Spool | Brass + NBR |
| 7 | Repositioning spring | Steel |

2

AIR TREATMENT

Design

Manual operated version

Pneumatic operated version

Solenoid operated version

Size 1 - Size 2
Size 3

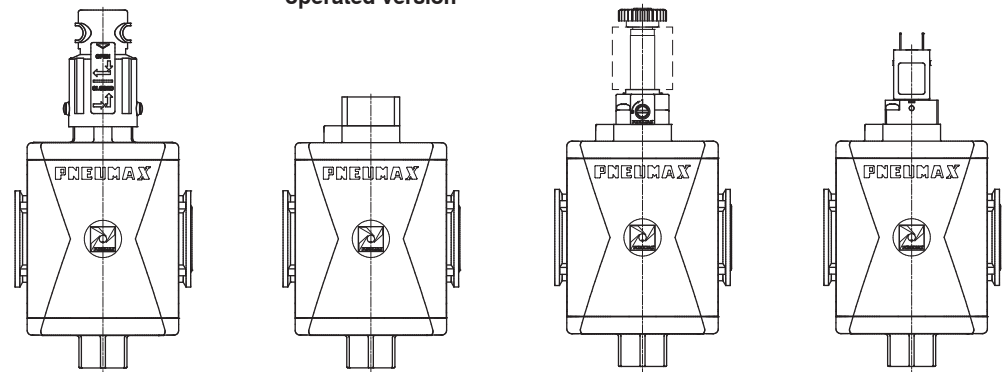

Size 4

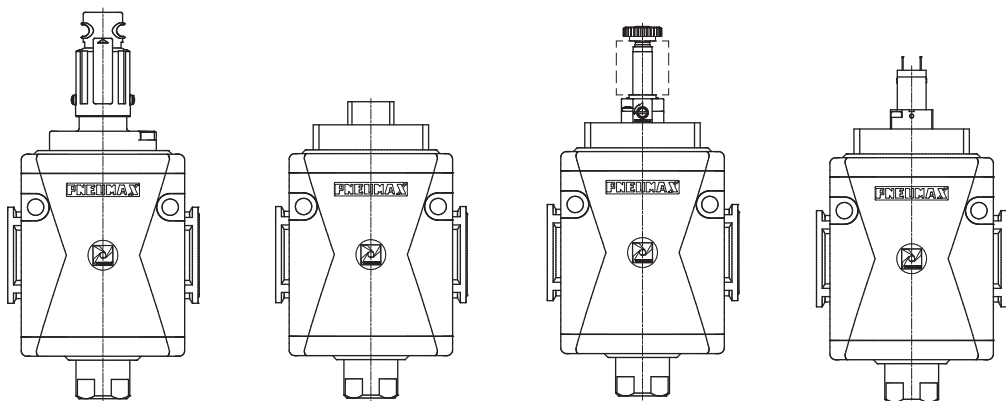



Order codes

T 17 3B V E A5

| Version |
|--|
| N : Technopolymer body and metal inserts (not available for size 4) |
| T : Technopolymer body and thread (not available for size 4) |
| P : Aluminum body (not available for size 1) |
| L : Aluminium body, low temperature (not available for solenoid version) |

| Size and connections |
|---|
| 1A : Size 1 - G1/8" only for N version |
| 1B : Size 1 - G1/4" only for T - N versions |
| 1C : Size 1 - 1/4" NPT only for N version |
| 2A : Size 2 - G1/4" only for N version |
| 2B : Size 2 - G3/8" for all versions |
| 2C : Size 2 - 3/8" NPT only for N version |
| 3A : Size 3 - G3/8" only for N version |
| 3B : Size 3 - G1/2" for all versions |
| 3C : Size 3 - 1/2" NPT only for N version |
| 4B : Size 4 - G1" only for P - L versions |

| Operator |
|---------------|
| L : Manual |
| P : Pneumatic |
| E : Solenoid |

| Coil options |
|--|
| 15 mm coil |
| A4 : 12 V DC |
| A5 : 24 V DC |
| A6 : 24 V AC (50-60 Hz) |
| A7 : 110 V AC (50-60 Hz) |
| A8 : 230 V AC (50-60 Hz) |
| A9 : 24 V DC (1 Watt) |
| 22 mm coil |
| B2 : Mechanical M2, without coil |
| B4 : 12 V DC |
| B5 : 24 V DC |
| B6 : 24 V AC (50-60 Hz) |
| B7 : 110 V AC (50-60 Hz) |
| B8 : 230 V AC (50-60 Hz) |
| B9 : 24 V DC (2 Watt) (Atex certification not available) |
| 30 mm coil |
| C5 : 24 V DC |
| C6 : 24 V AC (50-60 Hz) |
| C7 : 110 V AC (50-60 Hz) |
| C8 : 230 V AC (50-60 Hz) |
| C9 : 24 V DC (2 Watt) (Atex certification not available) |

Example : T173BVEA5 : Size 3 electric shut off valve G1/2", 15 mm coil, 24VDC

2 AIR TREATMENT

Dimensions

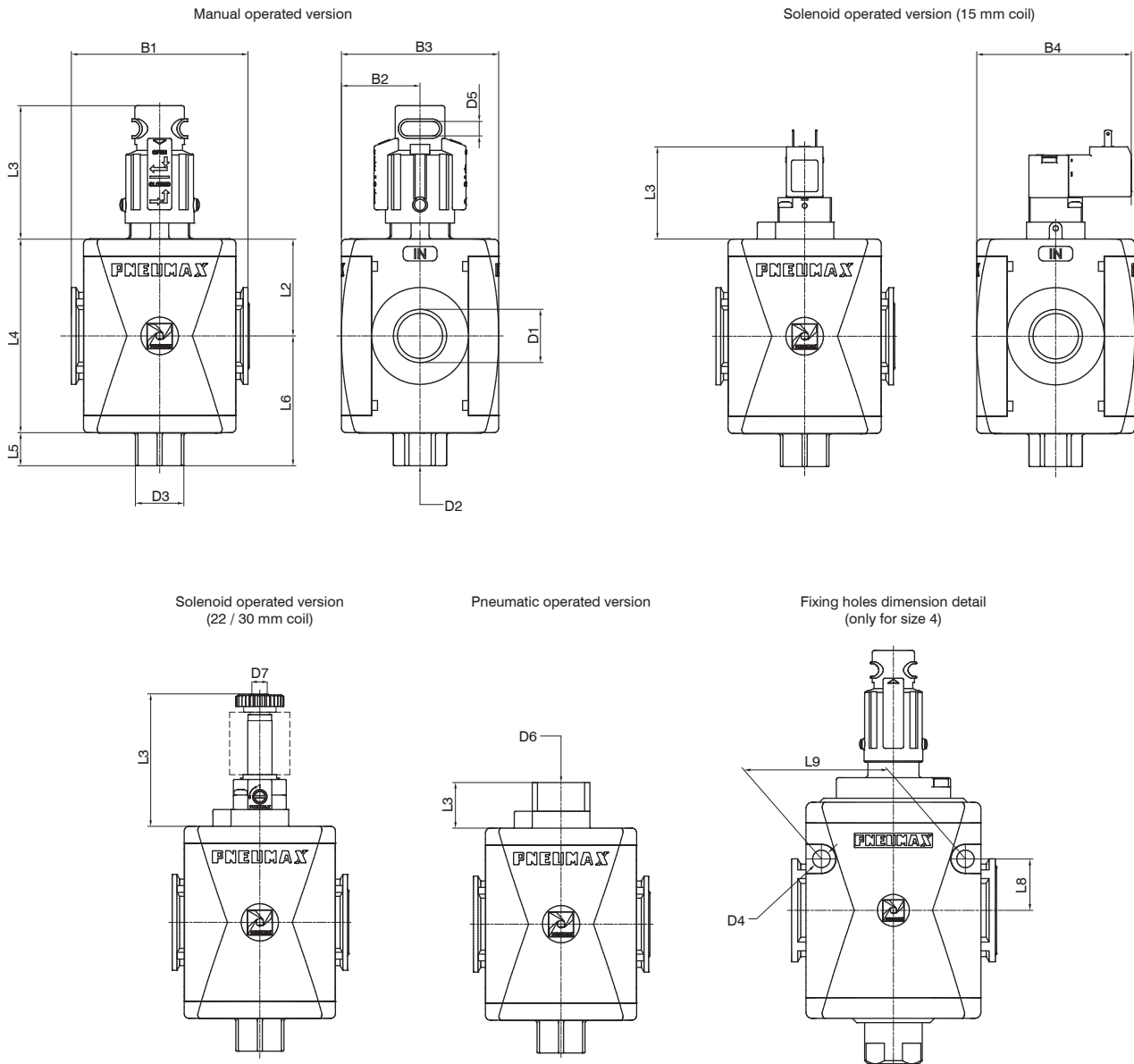

2
AIR TREATMENT

| Model | B1 | B2 | B3 | B4 | D1 | D2 | D3 | D4 | D5 | D6 | D7 | L2 | L3 | | | | L4 | L5 | L6 | L8 | L9 |
|--------|----|------|----|------|----------------------------|-------|-------|-----|----|-------|----|------|--------|-----------|-----------------------------|-----------------------|-----|----|------|----|----|
| | | | | | | | | | | | | | Manual | Pneumatic | Solenoid coil 22 or 30mm | Solenoid 15mm coil | | | | | |
| #171.. | 48 | 21 | 42 | 52 | G1/8" G1/4" 1/4" NPT | G1/4" | Ch.17 | / | 6 | G1/8" | M5 | 27,5 | 55 | 19 | 57 | 37,5 | 55 | 11 | 38,5 | / | / |
| #172.. | 62 | 28,5 | 57 | 59,6 | G1/4" G3/8" 3/8" NPT | G3/8" | Ch.20 | / | 6 | G1/8" | M5 | 34 | 54,2 | 22 | 60 | 40,3 | 68 | 14 | 48 | / | / |
| #173.. | 73 | 32,5 | 65 | 63,6 | G3/8" G1/2" 1/2" NPT | G3/8" | Ch.20 | / | 6 | G1/8" | M5 | 40 | 55 | 19 | 57 | 37,4 | 80 | 14 | 54 | / | / |
| #174.. | 99 | 44 | 88 | 75 | G1" | G1/2" | Ch.25 | 8,5 | 6 | G1/8" | M5 | 52,5 | 71,5 | 27 | 67 | 45,5 | 105 | 22 | 74,5 | 25 | 70 |

▶ **Progressive start-up valve (AP - APW)**



- ▶ Progressive start-up valve
- ▶ Available in 4 sizes with flow rates up to 15000 NI/min and connections from 1/8" to 1"
- ▶ Suitable for downstream system gradual pressurization
- ▶ Downstream circuit filling time regulated via a built in flow regulator
- ▶ Full pressure is allowed once the down stream circuit pressure reaches 50% of the inlet pressure
- ▶ ATEX certification (II 2GD or II 3GD)

2

AIR TREATMENT

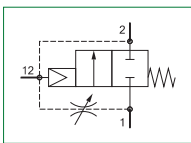

| Technical characteristics | | | | | |
|--|------------------|---|---|---|-----------------|
| Size | | Size 1 | Size 2 | Size 3 | Size 4 |
| Body and connections type | | Technopolymer body, integrated technopolymer connections (T version) Technopolymer body, metal connections (N version) | | | / |
| | | / | Aluminium body, integrated aluminium connections (P version) | | / |
| IN / OUT connections | T version | G1/4" | G3/8" | G1/2" | not available |
| | N version | G1/8" - G1/4" - 1/4" NPT | G3/8" - G1/4" - 3/8" NPT | G3/8" - G1/2" - 1/2" NPT | |
| | P version | not available | G3/8" | G1/2" | |
| Assembly configuration | | Stand alone / | | | Panel mounted |
| Assembly positions | | Indifferent | | | |
| Max. fittings torque IN / OUT connections | | G1/8" metal: 15Nm G1/4" metal: 20Nm G1/4" technopolymer: 9Nm | G1/4" metal: 20Nm G3/8" metal: 25Nm G3/8" technopolymer: 16Nm | G3/8" metal: 25Nm G1/2" metal: 30Nm G1/2" technopolymer: 22Nm | G1" metal: 35Nm |

| Operational characteristics | | | | |
|---|-------------|-------------|-------------|--------------|
| Size | Size 1 | Size 2 | Size 3 | Size 4 |
| Maximum working pressure | 13 bar | | | 10 bar |
| Minimum working pressure | 2,5 bar | | | |
| Working temperature | -5°C +50°C | | | |
| Nominal flow rate at 6 bar with Δp=1 (from 1 to 2) | 1400 NI/min | 2200 NI/min | 3600 NI/min | 15000 NI/min |
| Fully open flow control device maximum flow rate | 75 NI/min | 200 NI/min | 200 NI/min | 1000 NI/min |

| Weights | | | | | |
|----------------------------|------|--------|--------|--------|--------|
| | Size | Size 1 | Size 2 | Size 3 | Size 4 |
| Technopolymer body version | | 80 g | 150 g | 240 g | / |
| Aluminium body version | | / | 235 g | 370 g | 1100 g |

Materials

Exploded sectioned

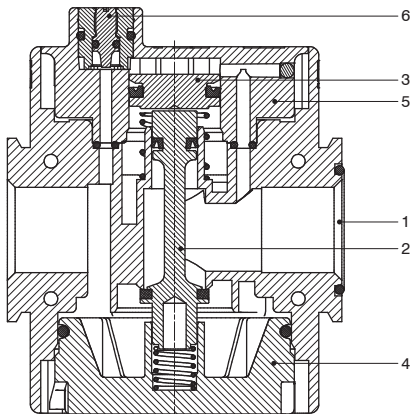

Progressive start-up valve

| | | |
|---|-------------------|---------------------------------|
| 1 | Body | Polyamide Die-cast aluminium |
| 2 | Drive pin | Aluminium |
| 3 | Piston | Aluminium |
| 4 | Rear end cap | Polyamide / Die-cast aluminium |
| 5 | Central support | Polyamide / Aluminium |
| 6 | Modulating needle | Brass |

2

AIR TREATMENT

Design

Size 1 - Size 2 - Size 3

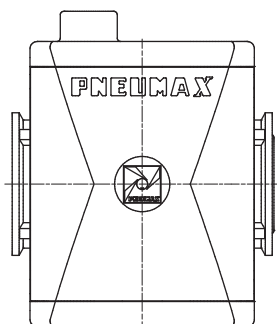

Size 4

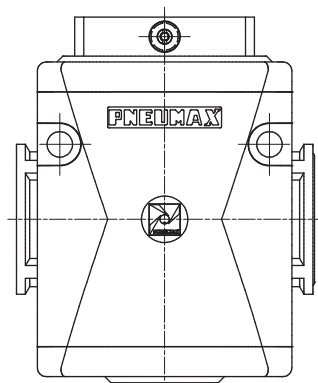



Order codes

T 17 3B AP

| Version |
|--|
| N : Technopolymer body and metal inserts (not available for size 4) |
| T : Technopolymer body and thread (not available for size 4) |
| P : Aluminum body (not available for size 1) |

| Size and connections |
|--|
| 1A : Size 1 - G1/8" only for N version |
| 1B : Size 1 - G1/4" only for T - N versions |
| 1C : Size 1 - 1/4" NPT only for N version |
| 2A : Size 2 - G1/4" only for N version |
| 2B : Size 2 - G3/8" for all versions |
| 2C : Size 2 - 3/8" NPT only for N version |
| 3A : Size 3 - G3/8" only for N version |
| 3B : Size 3 - G1/2" for all versions |
| 3C : Size 3 - 1/2" NPT only for N version |
| 4B : Size 4 - G1" only for P version |

| Flow direction (only for size 4) |
|----------------------------------|
| : : From left to right |
| W : From right to left |

Example : T173BAP : Size 3 progressive start-up valve G1/2"

2 AIR TREATMENT

Dimensions

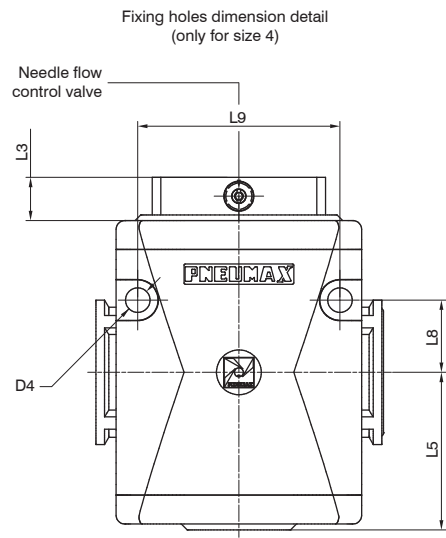
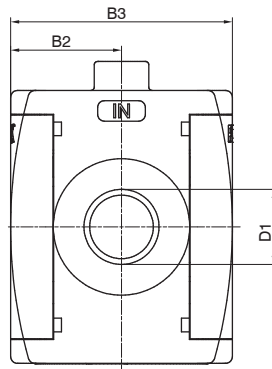
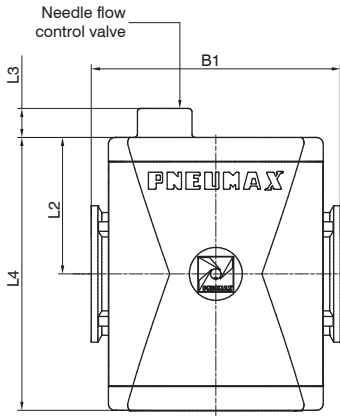

| Model | B1 | B2 | B3 | D1 | D4 | L2 | L3 | L4 | L5 | L8 | L9 |
|--------|----|------|----|----------------|-----|------|-----|-----|------|----|----|
| #171.. | 48 | 21 | 42 | G1/8" G1/4" | / | 27,5 | 12 | 55 | / | / | / |
| #172.. | 62 | 28,5 | 57 | G1/4" G3/8" | / | 34 | 9,2 | 68 | / | / | / |
| #173.. | 73 | 32,5 | 65 | G3/8" G1/2" | / | 40 | 8,7 | 80 | / | / | / |
| #174.. | 99 | 44 | 88 | G1" | 8,5 | 52,5 | 13 | 105 | 54,5 | 25 | 70 |

▶ Air intake (PA)



- ▶ Pneumatic by-pass
- ▶ Available with 2 threaded connections
- ▶ Atex certification (II 2GD or II 3GD)

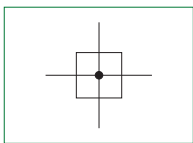

2
AIR TREATMENT

| Technical characteristics | | | | | |
|---|------------------|---|---|---|-----------------|
| Size | | Size 1 | Size 2 | Size 3 | Size 4 |
| Body and connections type | | Technopolymer body, integrated technopolymer connections (T version) Technopolymer body, metal connections (N version) | | | / |
| | | / | Aluminium body, integrated aluminium connections (P version) | | / |
| IN / OUT / INTAKE connections | T version | G1/4" | G3/8" | G1/2" | not available |
| | N version | G1/8" - G1/4" - 1/4" NPT | G3/8" - G1/4" - 3/8" NPT | G3/8" - G1/2" - 1/2" NPT | |
| | P version | not available | G3/8" | G1/2" | G1" |
| Assembly configuration | | Stand alone / | | | Panel mounted |
| Assembly positions | | Indifferent | | | |
| Max. fittings torque IN / OUT / INTAKE connections | | G1/8" metal: 15Nm G1/4" metal: 20Nm G1/4" technopolymer: 9Nm | G1/4" metal: 20Nm G3/8" metal: 25Nm G3/8" technopolymer: 16Nm | G3/8" metal: 25Nm G1/2" metal: 30Nm G1/2" technopolymer: 22Nm | G1" metal: 35Nm |

| Operational characteristics | | | | | |
|---------------------------------|--|------------|--------|--------|----------------------------------|
| Size | | Size 1 | Size 2 | Size 3 | Size 4 |
| Maximum working pressure | | 13 bar | | | 20 bar |
| Working temperature | | -5°C +50°C | | | -30°C +80°C (only for P version) |

| Weights | | | | | | |
|----------------------------|--|------|--------|--------|--------|--------|
| | | Size | Size 1 | Size 2 | Size 3 | Size 4 |
| Technopolymer body version | | | 52 g | 95,5 g | 151 g | / |
| Aluminium body version | | | / | 248 g | 370 g | 720 g |

Design

Size 1 - Size 2 - Size 3

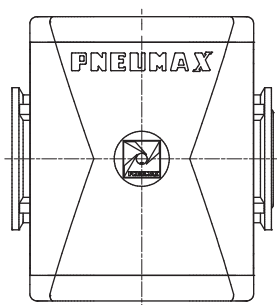

Size 4

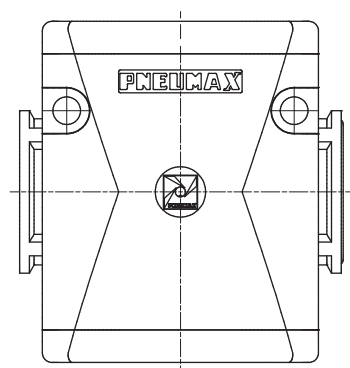



Order codes

T 17 3B PA

| Version |
|---|
| N : Technopolymer body and metal inserts (not available for size 4) |
| T : Technopolymer body and thread (not available for size 4) |
| P : Aluminium body (not available for size 1) |

| Size and connections |
|---|
| 1A : Size 1 - G1/8" only for N version |
| 1B : Size 1 - G1/4" only for T - N versions |
| 1C : Size 1 - 1/4" NPT only for N version |
| 2A : Size 2 - G1/4" only for N version |
| 2B : Size 2 - G3/8" for all versions |
| 2C : Size 2 - 3/8" NPT only for N version |
| 3A : Size 3 - G3/8" only for N version |
| 3B : Size 3 - G1/2" for all versions |
| 3C : Size 3 - 1/2" NPT only for N version |
| 4B : Size 4 - G1" only for P version |

Example : T173BPA : Size 3 air intake G1/2"

Dimensions

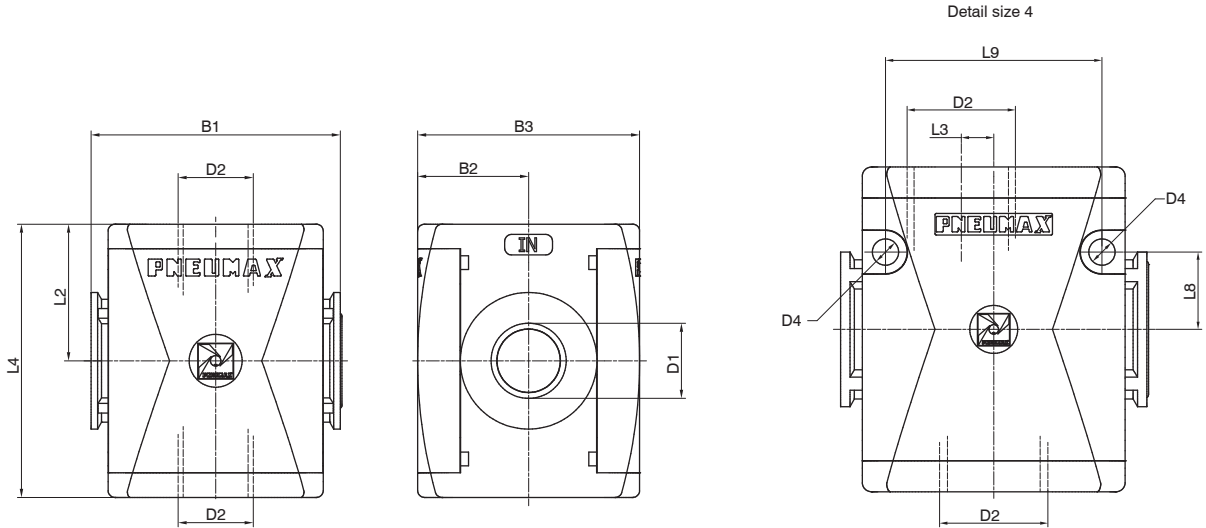

| Model | B1 | B2 | B3 | D1 | D2 | D4 | L2 | L3 | L4 | L8 | L9 |
|--------|----|------|----|----------------------------|-----|-----|------|------|-----|----|----|
| #171.. | 48 | 21 | 42 | G1/8" G1/4" 1/4" NPT | / | / | 27,5 | / | 55 | / | / |
| #172.. | 62 | 28,5 | 57 | G3/8" G1/4" 3/8" NPT | / | / | 34 | / | 68 | / | / |
| #173.. | 73 | 32,5 | 65 | G3/8" G1/2" 1/2" NPT | / | / | 40 | / | 80 | / | / |
| #174.. | 99 | 44 | 88 | G1" | 8,5 | 8,5 | 52,5 | 10,5 | 105 | 25 | 70 |

► Pressure switch (PP)



- 2 to 10 bar adjustable pressure switch with electrical connection
- The electrical connection is made by mean of a 15 mm connector (DIN 43650 type C)
- The microswitch contact could be normally closed or open (change overswitch)

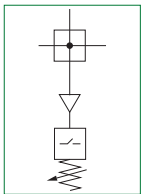

| Technical characteristics | | | | | |
|--|------------------|---|---|---|-----------------|
| Size | | Size 1 | Size 2 | Size 3 | Size 4 |
| Body and connections type | | Technopolymer body, integrated technopolymer connections (T version) Technopolymer body, metal connections (N version) | | | / |
| | | / | Aluminium body, integrated aluminium connections (P version) | | |
| IN / OUT / INTAKE connections | T version | G1/4" | G3/8" | G1/2" | not available |
| | N version | G1/8" - G1/4" - 1/4" NPT | G3/8" - G1/4" - 3/8" NPT | G3/8" - G1/2" - 1/2" NPT | |
| | P version | not available | G3/8" | G1/2" | G1" |
| Assembly configuration | | Stand alone / | | | Panel mounted |
| Assembly positions | | Indifferent | | | |
| Microswitch capacity | | 1A | | | |
| Microswitch maximum tension | | 250 VAC | | | |
| Microswitch IP Rating | | IP65 (with connector installed) | | | |
| Max. fitting torque IN / OUT / INTAKE connections | | G1/8" metal: 15Nm G1/4" metal: 20Nm G1/4" technopolymer: 9Nm | G1/4" metal: 20Nm G3/8" metal: 25Nm G3/8" technopolymer: 16Nm | G3/8" metal: 25Nm G1/2" metal: 30Nm G1/2" technopolymer: 22Nm | G1" metal: 35Nm |

| Operational characteristics | | | | | |
|---------------------------------|--|------------|--------|--------|--------|
| Size | | Size 1 | Size 2 | Size 3 | Size 4 |
| Maximum working pressure | | 13 bar | | | |
| Working temperature | | -5°C +50°C | | | |
| Operating pressure range | | 2 - 10 bar | | | |



| Weights | | | | | |
|----------------------------|------|--------|--------|--------|--------|
| | Size | Size 1 | Size 2 | Size 3 | Size 4 |
| Technopolymer body version | | 138 g | 179 g | 235 g | / |
| Aluminium body version | | / | 330 g | 780 g | 800 g |

Design

Size 1 - Size 2 - Size 3

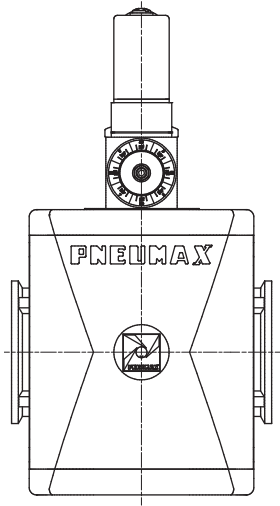

Size 4

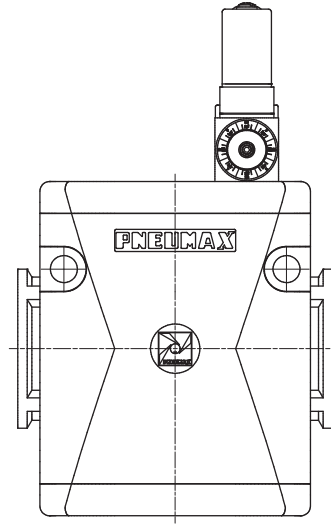

2
AIR TREATMENT

Order codes

T 17 3B PP

| Version |
|--|
| N : Technopolymer body and metal inserts (not available for size 4) |
| T : Technopolymer body and thread (not available for size 4) |
| P : Aluminum body (not available for size 1) |

| Size and connections |
|--|
| 1A : Size 1 - G1/8" only for N version |
| 1B : Size 1 - G1/4" only for T - N versions |
| 1C : Size 1 - 1/4" NPT only for N version |
| 2A : Size 2 - G1/4" only for N version |
| 2B : Size 2 - G3/8" for all versions |
| 2C : Size 2 - 3/8" NPT only for N version |
| 3A : Size 3 - G3/8" only for N version |
| 3B : Size 3 - G1/2" for all versions |
| 3C : Size 3 - 1/2" NPT only for N version |
| 4B : Size 4 - G1" only for P version |

| Flow direction (only for P version) |
|-------------------------------------|
| : : From left to right |
| W : From right to left |

Example : T173BPP : Size 3 pressure switch G1/2"

Dimensions

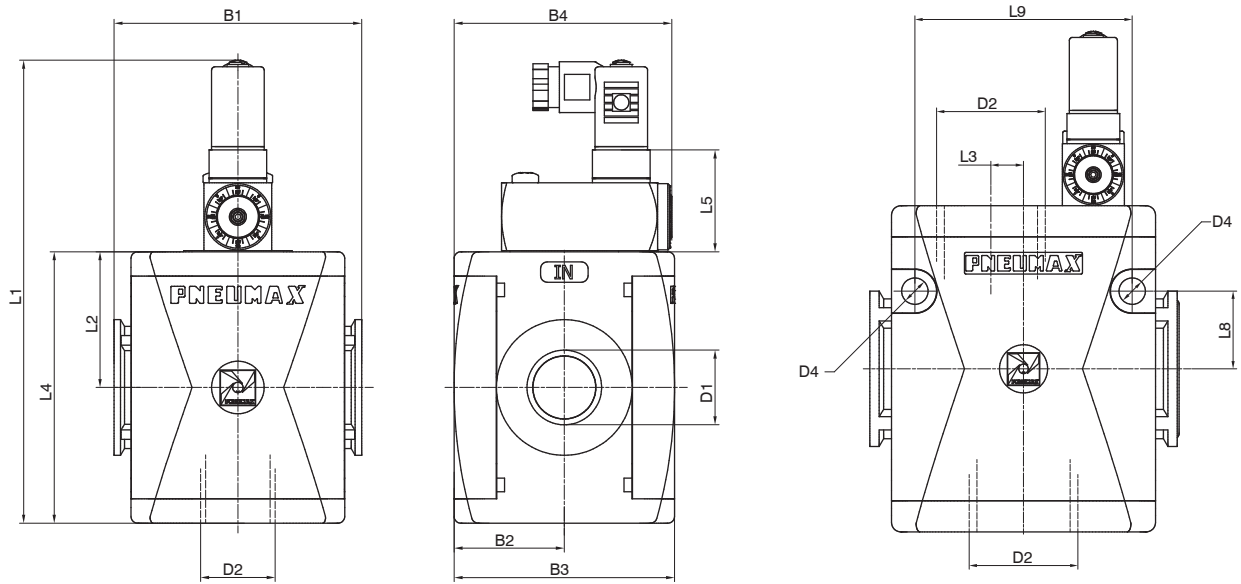

| Model | B1 | B2 | B3 | D1 | D2 | D4 | L1 | L2 | L3 | L4 | L5 | L8 | L9 |
|--------|----|------|----|----------------------------|-----|-----|-------|------|------|-----|------|----|----|
| #171.. | 48 | 21 | 42 | G1/8" G1/4" 1/4" NPT | / | / | 114,7 | 27,5 | / | 55 | 32,7 | / | / |
| #172.. | 62 | 28,5 | 57 | G3/8" G1/4" 3/8" NPT | / | / | 125 | 34 | / | 68 | 30 | / | / |
| #173.. | 73 | 32,5 | 65 | G3/8" G1/2" 1/2" NPT | / | / | 137 | 40 | / | 80 | 30 | / | / |
| #174.. | 99 | 44 | 88 | G1" | 8,5 | 8,5 | 162 | 52,5 | 10,5 | 105 | 30 | 25 | 70 |

Electrical connection

- 1 = neutral
- 2 = N.C. contact
- 3 = N.O. contact

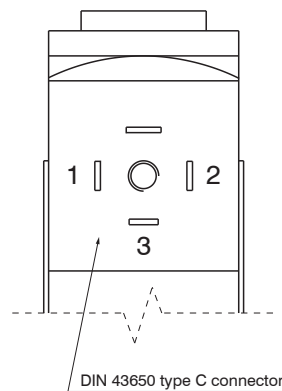

Air intake with pressure gauge or digital pressure switch integrated (PM-PW-PP-PZ)

- ▶ Available with pressure gauge or digital pressure switch integrated
- ▶ Air intake connection device available
- ▶ Material and version wide selection
- ▶ Available in 4 sizes with connections from 1/8" to 1"
- ▶ Atex certification (II 2GD or II 3GD)
for Integrated pressure gauge version

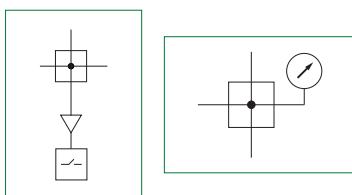
2
AIR TREATMENT

| Technical characteristics | | | | | |
|--|------------------|---|---|---|----------------|
| Size | | Size 1 | Size 2 | Size 3 | Size 4 |
| Body and connections type | | Technopolymer body, integrated technopolymer connections Technopolymer body, metal connections | | | / / |
| | | / | Aluminium body, integrated aluminium connections | | |
| IN / OUT connections | T version | G1/4" | G3/8" | G1/2" | not available |
| | N version | G1/8" - G1/4" - 1/4" NPT | G3/8" - G1/4" - 3/8" NPT | G3/8" - G1/2" - 1/2" NPT | |
| | P version | not available | G3/8" | G1/2" | G1" |
| Air intake connection | | G1/4" | G3/8" | G3/8" | G1/2" |
| Assembly configuration | | Stand alone / | | | Panel mounted |
| Assembly positions | | Indifferent | | | |
| Pressure measurement | | Integrated pressure gauge Digital pressure switch | | | |
| Max. fittings torque IN / OUT connections | | G1/8" metal: 15Nm G1/4" metal: 20Nm G1/4" technopolymer: 9Nm | G1/4" metal: 20Nm G3/8" metal: 25Nm G3/8" technopolymer: 16Nm | G3/8" metal: 25Nm G1/2" metal: 30Nm G1/2" technopolymer: 22Nm | G1"metal: 35Nm |

| Operational characteristics | | | | |
|---|------------|--------|------------------------------------|--------|
| Size | Size 1 | Size 2 | Size 3 | Size 4 |
| Maximum working pressure | 13 bar | | | |
| Working temperature with integrated pressure gauge | -5°C +50°C | | -30°C +80°C (only with metal body) | |
| Working temperature with digital pressure switch | 0°C +50°C | | | |

| Weights | | | | | |
|--|------|--------|--------|--------|--------|
| | Size | Size 1 | Size 2 | Size 3 | Size 4 |
| Technopolymer body version with Integrated pressure gauge | | 83 g | 161 g | 249 g | / |
| Technopolymer body version with integrated digital pressure switch | | 111 g | 189 g | 277 g | / |
| Aluminium body version with Integrated pressure gauge | | / | 245 g | 373 g | 947 g |
| Aluminium body version with integrated digital pressure switch | | / | 273 g | 401 g | 963 g |

Design

Size 1 - Size 2 - Size 3
Technopolymer body and
integrated pressure
gauge

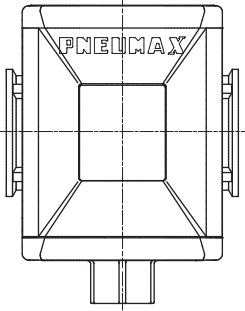

Size 1 - Size 2 - Size 3
Technopolymer body and
integrated digital
pressure switch

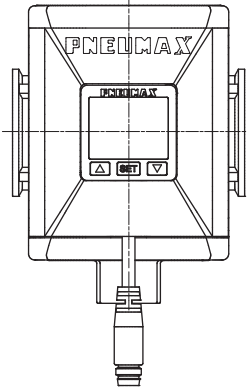

Size 2 - Size 3
Aluminium body and
integrated pressure
gauge

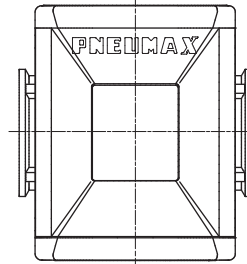

Size 2 - Size 3
Aluminium body and
integrated digital
pressure switch

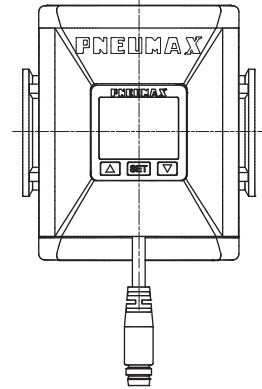

Size 4
Integrated pressure
gauge version

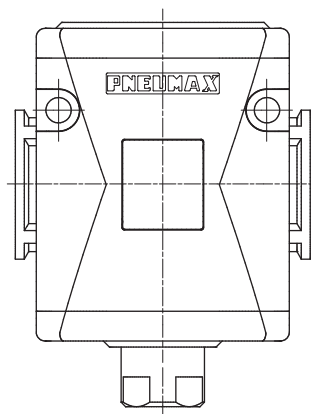

Size 4
Integrated digital
pressure switch version

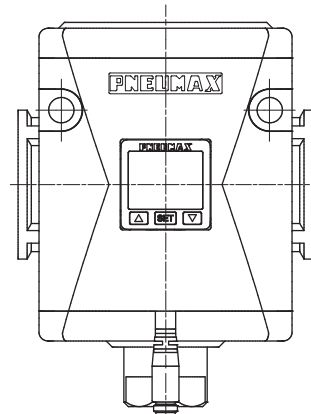



Order codes

T 17 3B P P A

| Version |
|---|
| N : Technopolymer body and metal inserts (not available for size 4) |
| T : Technopolymer body and thread (not available for size 4) |
| P : Aluminum body (not available for size 1) |

| Size and connections |
|---|
| 1A : Size 1 - G1/8" only for N version |
| 1B : Size 1 - G1/4" only for T - N versions |
| 1C : Size 1 - 1/4" NPT only for N version |
| 2A : Size 2 - G1/4" only for N version |
| 2B : Size 2 - G3/8" for all versions |
| 2C : Size 2 - 3/8" NPT only for N version |
| 3A : Size 3 - G3/8" only for N version |
| 3B : Size 3 - G1/2" for all versions |
| 3C : Size 3 - 1/2" NPT only for N version |
| 4B : Size 4 - G1" only for P version |

| Pressure measurement options |
|--|
| M : Integrated pressure gauge |
| W : Integrated pressure gauge Right - Left |
| P : Digital pressure switch |
| Z : Digital pressure switch Right - Left |

| Digital pressure switch options |
|---------------------------------|
| A : Cable 150 mm + M8 PNP |
| B : Cable 150 mm + M8 NPN |
| C : Cable 2 m PNP |
| D : Cable 2 m NPN |

Example : T173BPPA : M8 PNP digital pressure switch, size 3 G1/2"

2 AIR TREATMENT

Dimensions - Integrated pressure gauge version

Technopolymer body version

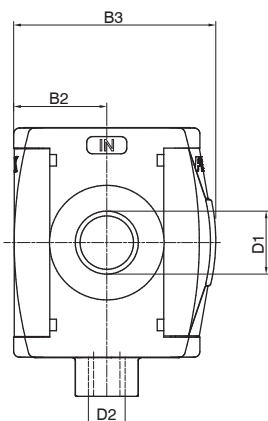
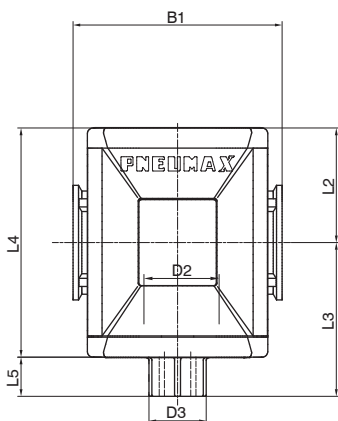

Fixing holes dimension detail (only for size 4)

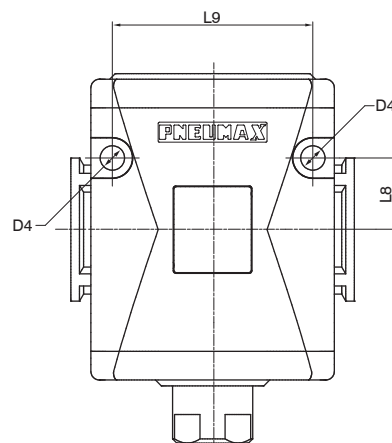

Aluminium body version (Size 2 - Size 3)

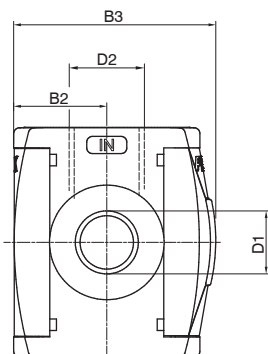
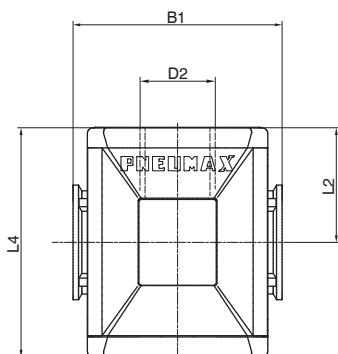

| Model | B1 | B2 | B3 | D1 | D2 | D3 | D4 | L2 | L3 | L4 | L5 | L8 | L9 |
|--------|----|------|------|----------------------------|-------|--------|-----|------|------|-----|----|----|----|
| #171.. | 48 | 21 | 48,5 | G1/8" G1/4" 1/4" NPT | G1/4" | Ch. 17 | / | 27,5 | 38,5 | 55 | 11 | / | / |
| #172.. | 62 | 28,5 | 62,5 | G1/4" G3/8" 3/8" NPT | G3/8" | Ch. 20 | / | 34 | 48 | 68 | 14 | / | / |
| #173.. | 73 | 32,5 | 70,5 | G3/8" G1/2" 1/2" NPT | G3/8" | Ch. 20 | / | 40 | 54 | 80 | 14 | / | / |
| #174.. | 99 | 44 | 90,5 | G1" | G1/2" | Ch. 25 | 8,5 | 52,5 | 74,5 | 105 | 22 | 25 | 70 |

Variable dimensions - Digital pressure switch version

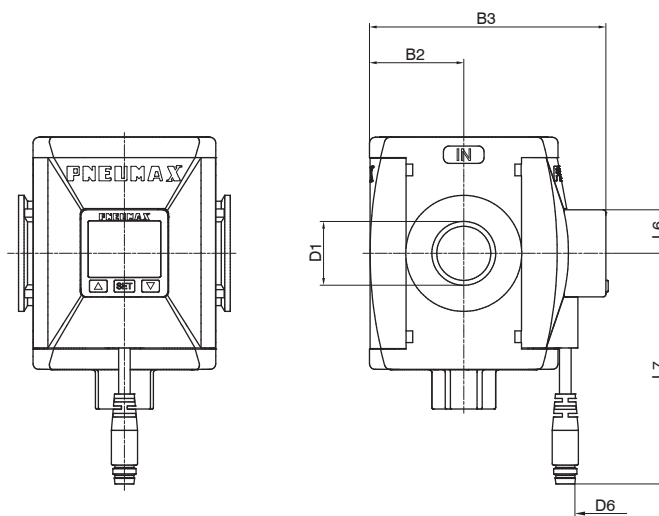

2

AIR TREATMENT

| Model | B2 | B3 | D1 | D6 - Type of digital pressure switch | | L6 | L7 - Type of digital pressure switch | |
|--------|------|-------|----------------------------|--------------------------------------|---------------------|----|--------------------------------------|-------|
| | | | | A - B | C - D | | A - B | C - D |
| #171.. | 21 | 60 | G1/8" G1/4" 1/4" NPT | M8 - 3 PIN | 3 x 0,129 mm, Ø4 mm | 15 | 150 | 2000 |
| #172.. | 28,5 | 73,5 | G1/4" G3/8" 3/8" NPT | | | | | |
| #173.. | 32,5 | 81,5 | G3/8" G1/2" 1/2" NPT | | | | | |
| #174.. | 44 | 101,5 | G1" | | | | | |

► **Digital pressure switch**



- 3 color digital LCD display, easy readout
- 4 units of measurement for pressure indication
- Optional PNP or NPN digital output
- N.O. and N.C. output contact selection directly on the digital pressure switch
- Available with M8-3PIN connector or 3 wire cable length 2 m
- Available only in combination with a air intake

2

AIR TREATMENT

Output circuit wiring diagrams

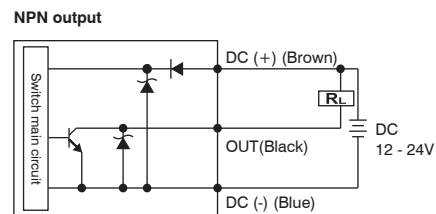
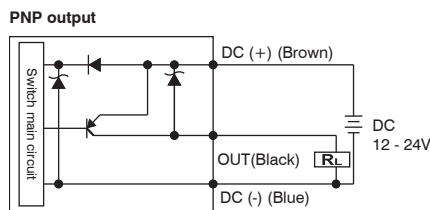

Digital pressure switch lay out

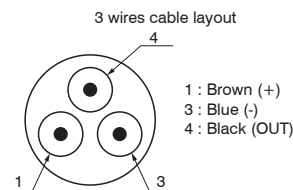
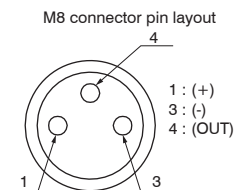

Cable ordering code

- MCH1** : cable 3 wires l=2,5m with M8 connector
- MCH2** : cable 3 wires l=5m with M8 connector
- MCH3** : cable 3 wires l=10m with M8 connector



| Technical characteristics | |
|--------------------------------|---|
| Pressure range and display | 0 - 10 bar |
| Max. inlet pressure | 15 bar |
| Fluid | 40µm filtered and dehumidified air |
| Display unit of measurement | MPa - kgf/cm ² - bar - psi |
| Supply voltage | 12 - 24 VDC |
| Current consumption | ≤40mA (without load) |
| Digital output type | PNP - NPN |
| Type of contact output | Normally Open - Normally Closed |
| Max. load current | 125 mA |
| Digital output activation mode | single threshold with fixed hysteresis - window with fixed hysteresis - window without hysteresis |
| Digital output activation time | 0.05s - 0.25s - 0.5s - 1s - 2s - 3s (selections for chattering-proof options) |
| Display characteristics | Double 3 1/2 digit display Digital output status indication Three-pushbuttons touchpad |
| Indicator accuracy | ≤ ±2% full scale value ± 1 digit |
| IP Rating | IP40 |
| Working temperature | 0°C + 50°C |
| Cable section | 3 x 0,129mm ² , Ø4 mm, PVC |

Supply and discharge valves SAFELINE



General

Upon implementation of the AIRPLUS TG3 series, air-treatment units, PNEUMAX develops a supply and discharge valve, with an electropneumatic control and spring-return, fitted with a diagnostic system regarding the state of the valve, with the possibility of creating a double channel to determine the system's redundancy. The valve, as a safety feature, provides the interruption of the air supply and the exhaust of the air circuit it is connected to. The version with one single channel emphasises the features of an EV 3/2 NC, monostable with electropneumatic control and spring-return, whose operation involves:

- condition of the VALVE AT REST, with a DE-ENERGISED coil; Port 1 (air supply) is not been connected to Port 2 (downstream air circuit). Port 2 is discharged out of Port 3;
- condition of the VALVE ACTIVATED, with an ENERGISED coil; Port 1 (air supply) is connected to Port 2 (downstream air circuit), with Port 3 (Discharge) closed.

By de-energising the coil, the system resets the condition of VALVE AT REST by means of the return spring, which repositions the spool. Once again Port 2 (downstream air circuit), discharges via Port 3. The state of the valve is constantly monitored by a diagnostic system, using a Hall effect sensor, which reads the position of the spool and consequently takes note of the valve's position.

The sensor is in the ON position when the valve is at rest (DE-ENERGISED coil), while it is in the OFF position when the valve is activated (ENERGISED coil).

The sensor is in the OFF position under conditions of an activated valve (DE-ENERGISED coil), indicating a possible problem.

The SAFELINE supply and discharge valve in the single version is a classified component in CATEGORY 2 according to ISO EN 13849 and is appropriate for use in safety circuits until PL=C.

The version with a double redundant channel is made using two single solenoid valves 3/2 NC provided with diagnostics, mounted in series so that the Port 2 of the first solenoid valve is linked to the Port 1 of the second solenoid valve. It is sufficient that only one of the EV is de-energised to guarantee the discharge of the air circuit. If one of the two EV must remain blocked due to a malfunction, the other one ensures the discharge function of the pneumatic installation. Even in this case, the diagnostic system of both solenoid valves constantly monitors the state of the 2 single EV.

The SAFELINE supply and discharge valve in the double version is a classified component in CATEGORY 4 according to ISO EN 13849 and is appropriate for use in safety circuits until PL=E.

Both single and double solenoid valves are provided with the following certifications released by BUREAU VERITAS:

- TYPE APPROVAL certificate according to the EN ISO 13849 regulations
- certification of examination of compliance in accordance to the machinery directive 2006/42/CE

The AIRPLUS SAFELINE are solenoid valves marked as ATEX →

| |
|--|
| II 3G Ex nA IIC T6 Gc (X) II 3D Ex tc IIIC T=80°C Dc (X) IP65 |
|--|



Construction characteristics

| | |
|----------------------|----------------------------------|
| Body | Aluminium |
| Operatore Solenoide | Technopolymer |
| Rear end cap | Aluminium |
| Spool | Aluminium |
| Spool seals | Polyurethane |
| Piston | Aluminium |
| Spring | EN 10270-1 DH steel |
| Electrical Interface | Male MP12 4 PIN TYPE A connector |

Operational characteristics

| | |
|--------------------------|---|
| Fluid | Filtered air. No lubrication needed, if applied it shall be continuous. |
| Working temperature | -10°C +50°C |
| Minimum working pressure | 2,5 bar |
| Maximum working pressure | 10 bar |

ASSEMBLY AND INSTALLATION:

Undertake the installation respecting the safety requirements with regards to the system and components for hydraulic and pneumatic transmissions. Install the device as close as possible to the point of use. Its assembly is possible in any position. Pay attention to the flow direction, indicated on the main body with the labels IN and OUT. During the components discharge, high levels of noise occur. The use of a silencer on the discharge port is recommended. Ensure there is sufficient space for assembly during the installation process. Please ensure that the discharge area is always clear, and in case a silencer is used, periodically verify that it is not obstructed. It is possible to integrate and install the device in an existing AIRPLUS group or in a new installation, or else to use the device individually attaching it by aligning the assembled unit with the relevant fastening flange for the supply and discharge valve, or to use the device individually attaching it by aligning the assembled unit with the type "Y" fastening flange for the double supply and discharge valve.

2

AIR TREATMENT



WARNING!

Pay particular attention to external factors such as the nearness of live wires, magnetic fields, metallic objects providing magnetic conduction very close to the device, which may influence and disturb the diagnostic system.



WARNING!

The electrical connection must be made exclusively by specialized personnel, using components that have no voltage present. Only use power supplies which can guarantee a safe electrical isolation of the working voltage in accordance to IEC/EN 60204-1. Additionally, observe the requirements anticipated by the PELV circuits in accordance to IEC/EN 60204-1.

CARE AND MAINTENANCE



WARNING!

Do not connect or disconnect the device when energised! Do not open and/or disassemble the parts that are included in the energised valve. Once the power supply is disconnected, wait for a few minutes before opening or disassembling parts of the valve that result in its disassembly.

Before carrying out any operation, it is essential to remove the pneumatic and power supply to the device and wait for the residual pressure to be completely discharged.

Please ensure that the discharge is always clear, and in case a silencer is used, periodically verify that it is not obstructed.

Periodically remove any dust deposits from the valve using a damp cloth. Use soapy water to clean the device.

Do not use corrosive or alcohol-based products.

For maintenance operations on internal components, please consult with PNEUMAX SPA.

Supply and discharge valve single (VS)

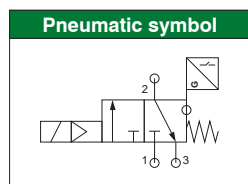

ATEX CE II
II 3G Ex nA IIC T6 Gc (X)
II 3D Ex tc IIIC T=80°C Dc (X) IP65



Electrical connection

| PIN | Description |
|-----|------------------|
| 1 | +24 VDC (Sensor) |
| 2 | +24 VDC (EV) |
| 3 | GND (Sensor+EV) |
| 4 | SENSOR OUTPUT |

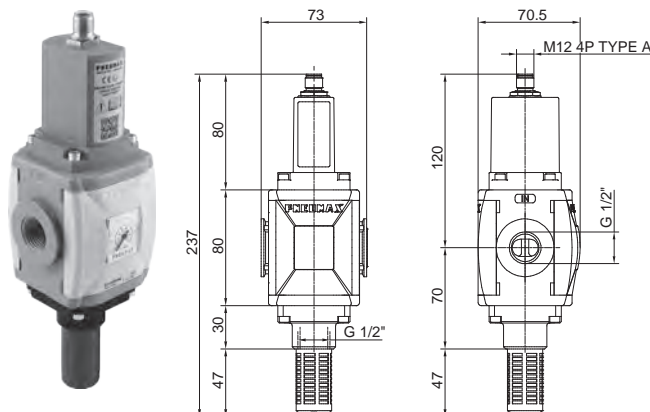
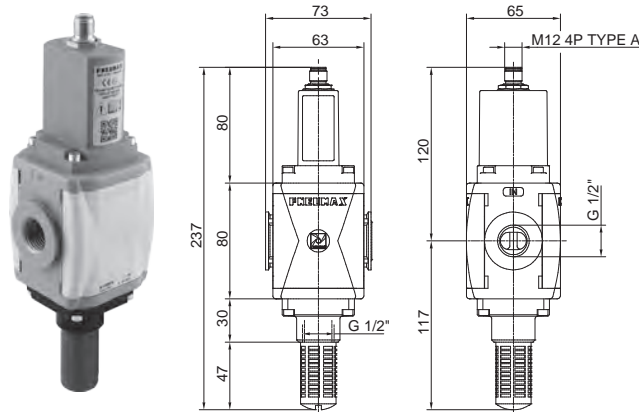
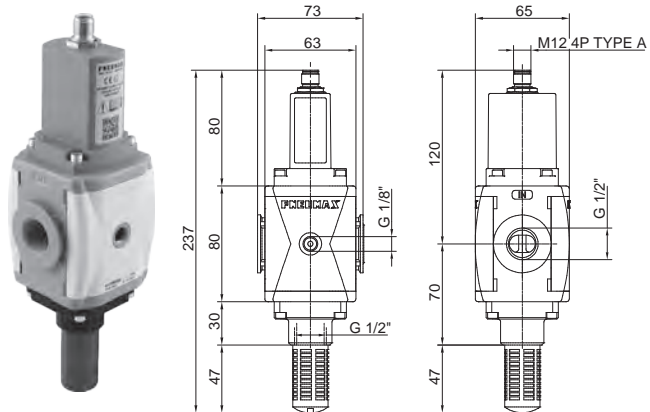

Dimensions with fixing bracket mounted

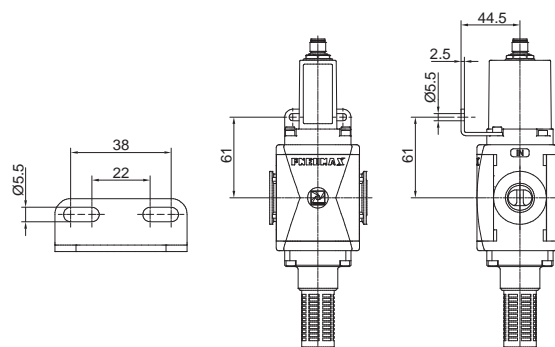

2
AIR TREATMENT

| Electrical characteristics | | Technical characteristics | | Ordering code |
|---|--|---|---|---|
| Electrical connection | Male M12 4 PIN TYPE A connector | Connections | G1/2" UNI-ISO 228/1 | N173BVS00 |
| Coil Features | 24VDC, 1 Watt | Fluid | Filtered air. No lubrication needed, if applied it shall be continuous. | |
| Suppressor diode for coil reverse voltage spike | Present | Function | 3/2 N.C. monostable | V = Standard* (without connections) M = Integrated pressure gauge W = Integrated pressure gauge (Right-Left) G = G1/8" pressure gauge connection |
| Supply voltage allowance | -5% +10% | Minimum working pressure | 2,5 bar | |
| Electrical characteristics of sensor | | Maximum working pressure | 10 bar | FIXING = Without fixing* 01 = Fixing bracket mounted (Left-Right) 02 = Fixing bracket mounted (Right-Left) |
| Sensor characteristics | 10 - 30V DC | Working temperature | -10°C +50°C | |
| Operating principle | Hall effect | Flow rate at 6bar Δp (from 1 to 2) | 3500 NL/min | 0 * no additional letter required |
| Contact type | N.O. | Flow rate at 6bar Δp (from 2 to 3) | 2000 NL/min | |
| Output type | PNP | Flow rate at 6bar (from 2 to 3) with free discharge | 3800 NL/min | |
| Permanent maximum current | 100 mA | Type of installation | Stand alone | |
| Permanent maximum power | 3 Watt | Assembly positions | Indifferent | |
| Voltage drop max. | 2 V | Noise level | 90 dB | |
| Safety characteristics | | Response time ON ISO 12238 | 36 ms | |
| Regulatory compliance | EN ISO 13849-1 | Response time OFF ISO 12238 | 76 ms | |
| Safety function fulfilled | Interruption of supply and unloading of the downstream pneumatic circuit | IP Rating | IP65 (with connector installed) | |
| Performance Level (PL) | c | | | |
| UNI EN 13849 category | 2 | | | |
| Safety Integrity Level (SIL) | 1 | | | |
| PFH _d | 1,7*10 ⁻⁶ | | | |
| CE marking | In accordance with the EU Machinery Directive, annex V | | | |

Installation tip of a safety system by means of a single valve

Please note: the safety valve is not sufficient alone to guarantee the safety function. Its setup requires the use of a monitoring device.

In this setup, the SIEMENS® 3SK1112-1BB40 monitoring device has been indicated, activated by an S2 start / reset pushbutton, blocked by an S1 emergency shutdown key.

Said monitoring device, by means of the readings of the sensor placed inside the valve (reading made by means of the K1 relay), operates the activation of the valve itself. The monitoring device transmits the safety status as an output.

The preliminary estimate and the final verification of the achieved PL are the responsibility of the designer of the part of the system dedicated to providing the safety function.

Note: with a single valve, it is not possible to obtain a PL greater than “c”.

Setup suggestions

- The double stop pushbutton is connected to clamps T1-IN1 and T2-IN2 of 3SK1112-1BB40.
- The start / reset pushbutton is connected between +24 V and the INS clamp of 3SK1112-1BB40.
- The valve is supplied between 0 V (Pin 3 of the supply connector) and the 14 clamp of 3SK1112-1BB40 (Pin 2 of the supply connector).
- The HALL effect sensor is supplied between 0 V (Pin 3 of the supply connector) and 24 V (Pin 1 of the supply connector).
- The HALL effect sensor drives (Pin 4 of the supply connector) the K1 relay, whose N.A. contact will be connected between the monitoring device's clamp T2 and INF.

The circuit diagram of the **suggested** configuration is provided, along with the configuration of 3SK1112-1BB40.

2 AIR TREATMENT

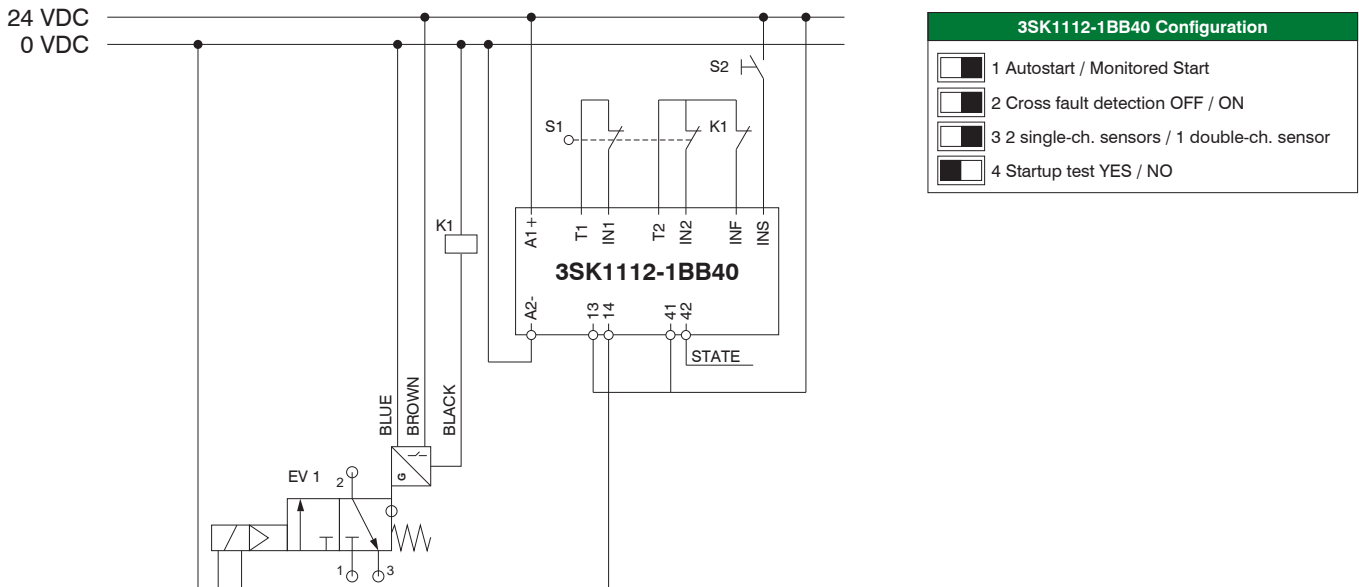

Analysis of malfunctions

The diagnostic system (monitoring device plus sensor) has the purpose of verifying the appearance of malfunctions within the valve that undermine the safety function. In particular, (with 3SK1112-1BB40 configured as in the illustration), the K1 relay prevents resetting the system by means of S2 when the coil is de-energised, but the sensor remains in the OFF position (K1 remains de-energised).

Supply and discharge valve double (V2S)

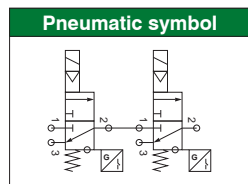

ATEX CE Ex
II 3G Ex nA IIC T6 Gc (X)
II 3D Ex tc IIIC T=80°C Dc (X) IP65



Electrical connection

| PIN | Description |
|-----|------------------|
| 1 | +24 VDC (Sensor) |
| 2 | +24 VDC (EV) |
| 3 | GND (Sensor+EV) |
| 4 | SENSOR OUTPUT |

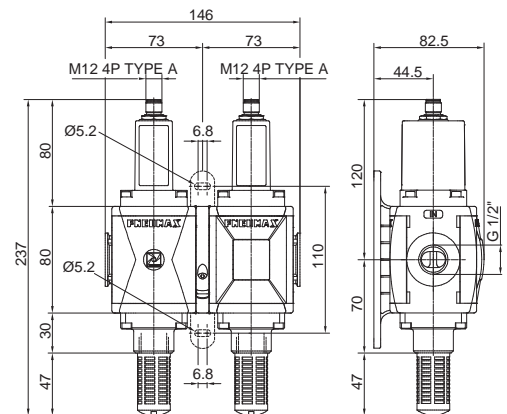
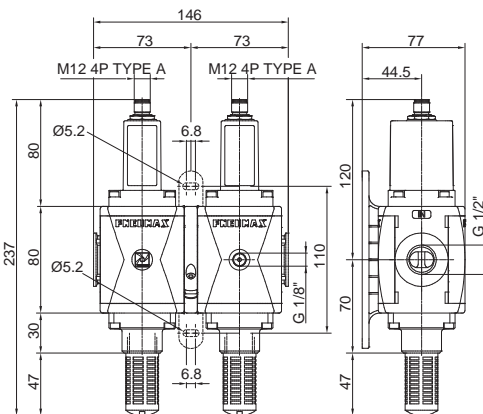
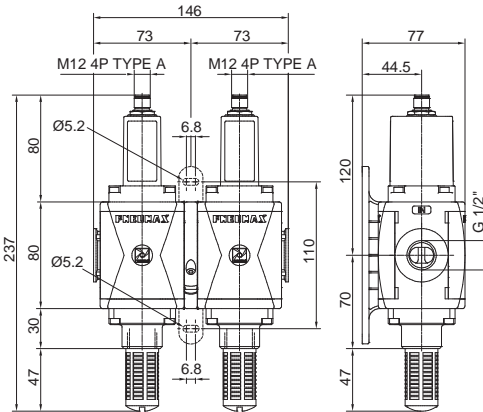

2

AIR TREATMENT

| Electrical characteristics | | Technical characteristics | | Ordering code |
|---|--|---|---|---|
| Electrical connection | Male M12 4 PIN TYPE A connector | Connections | G1/2" UNI-ISO 228/1 | N173BV2S000 VERSIONS = Standard* (without connections) M = Integrated pressure gauge G = G1/8" pressure gauge connection FIXING X = Flange X Y = Flange Y K = Aluminium flange Y Z = Aluminium flange X FLOW RATE DIRECTION = Standard* (Left-Right) W = (Right-Left) * no additional letter required |
| Coil Features | 24VDC, 1 Watt + 1 Watt | Fluid | Filtered air. No lubrication needed, if applied it shall be continuous. | |
| Suppressor diode for coil reverse voltage spike | Present | Function | 3/2 N.C. monostable | |
| Supply voltage allowance | -5% +10% | Minimum working pressure | 2,5 bar | |
| Electrical characteristics of sensor | | Maximum working pressure | 10 bar | |
| Sensor characteristics | 10 - 30V DC | Working temperature | -10°C +50°C | |
| Operating principle | Hall effect | Flow rate at 6bar Δp (from 1 to 2) | 2500 NL/min | |
| Contact type | N.O. | Flow rate at 6bar Δp (from 2 to 3) | 2000 NL/min | |
| Output type | PNP | Flow rate at 6bar (from 2 to 3) with free discharge | 3800 NL/min | |
| Permanent maximum current | 100 mA + 100 mA | Type of installation | Stand alone | |
| Permanent maximum power | 3 Watt + 3 Watt | Assembly positions | Indifferent | |
| Voltage drop max. | 2 V + 2 V | Noise level | 90 dB | |
| Safety characteristics | | Response time ON ISO 12238 | 68 ms | |
| Regulatory compliance | EN ISO 13849-1 | Response time OFF ISO 12238 | 79 ms | |
| Safety function fulfilled | Interruption of supply and unloading of the downstream pneumatic circuit | IP Rating | IP65 (with connector installed) | |
| Performance Level (PL) | e | | | |
| UNI EN 13849 category | 4 | | | |
| Safety Integrity Level (SIL) | 3 | | | |
| PFH _d | 4,7*10 ⁻⁶ | | | |
| CE marking | In accordance with the EU Machinery Directive, annex V | | | |

Installation tip of a safety system by means of a double valve

Please note: the safety valve is not sufficient alone to guarantee the safety function. Its setup requires the use of a monitoring device.

In this setup, the SIEMENS 3SK2112 monitoring device has been indicated, activated by an S2 start / reset pushbutton, blocked by an S1 emergency shutdown key. Said monitoring device, by means of the readings of the sensors placed inside the double valve, operates the activation of the valve itself. The preliminary estimate and the final verification of the achieved PL are the responsibility of the designer of the part of the system dedicated to provide the safety function.

Setup suggestions

- The double stop pushbutton is connected to clamps T1-F-IN1 and T2-F-IN2 of 3SK2112.
- The start /reset pushbutton is connected between +24 V and the F-IN10 clamp of 3SK2112.

The double valve, for notation simplicity, is indicated as consisting of 2 valves: EV1 and Ev2

EV1

- The valve is supplied between 0 V (Pin 3 of the supply connector) and the F-Q1 clamp of 3SK2112 (Pin 2 of the supply connector).
- The HALL effect sensor is supplied between 0 V (Pin 3 of the supply connector) and 24 V (Pin 1 of the supply connector).
- The HALL effect sensor is attached (Pin 4 of the supply connector) to the monitoring device's F-IN3 clamp.

EV2

- The valve is supplied between 0 V (Pin 3 of the supply connector) and the F-Q2 clamp of 3SK2112 (Pin 2 of the supply connector).
- The HALL effect sensor is supplied between 0 V (Pin 3 of the supply connector) and 24 V (Pin 1 of the supply connector).
- The HALL effect sensor is attached (Pin 4 of the supply connector) to the monitoring device's F-IN4 clamp.

The circuit diagram of the **suggested** configuration is provided.

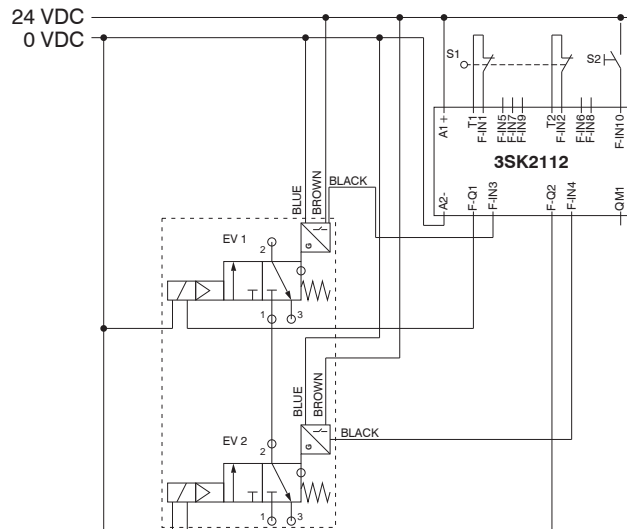

Analysis of malfunctions

The diagnostic system (monitoring device plus sensors) has the purpose of verifying the appearance of malfunctions within the valves, which undermine the safety function. In particular, the monitoring device must be appropriately programmed to avoid the system's reset by means of S2 when both coils are de-energised and at least one sensor remains in an OFF position.

Accessories

Pressure gauge

17070 **A** **C**

| Version | |
|------------|------------|
| A : | Dial Ø40 |
| B : | Dial Ø50 |
| Scale | |
| A : | 0 - 4 bar |
| B : | 0 - 6 bar |
| C : | 0 - 12 bar |

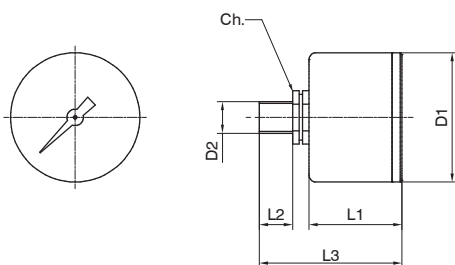

| Model | L1 | L2 | L3 | D1 | D2 | Ch |
|----------|----|----|----|----|-----------|----|
| 17070A.. | 26 | 10 | 44 | 41 | Gc - 1/8" | 14 |
| 17070B.. | 27 | 10 | 45 | 49 | Gc - 1/8" | 14 |



Regulatory Framework

The purpose of the EU's Machinery Directive is to define the health and safety requirements in the framework of designing and constructing machinery. Since 2009, the new Machinery Directive has become effective in the European Union. Member countries of the EU are required to implement this standard.

The manufacturers of machinery can comply with the Machinery Directive applying the harmonised standards listed in the Official Journal of the European Union.

The design and manufacture of safety controls are developed in compliance with one of the two important harmonised standards:

| UNI EN ISO 13849-1 |
|---|
| Safety of machinery Safety-related parts of control systems Part 1: General design principles |

| EN 62061 |
|--|
| Safety of machinery Functional safety of electrical, electronic and programmable control systems regarding safety |

The UNI EN ISO 13849-1 standard is one of the most important harmonised standards, which has been widely used; it is intended to provide a guide to principles for design and integration of safety-related parts of the control system.

Each safety-related control system must be designed and constructed in accordance with the principles of ISO 12100 and ISO 14121 by which the possible risks are considered and assessed, in view of the intended uses and the reasonably anticipated incorrect uses.

The parts of a machinery's control system are called "Safety-related parts of control systems". Their capacity to perform a safety function under predictable conditions is assigned by means of five possible levels called "performance levels" (PL). These levels are defined in terms of probability of dangerous malfunction per hour.

| PL - Performance Level | Average probability of dangerous malfunction per hour (1/h) |
|------------------------|---|
| a | $\geq 10^{-5}$ to $< 10^{-4}$ |
| b | $\geq 3 \times 10^{-6}$ to $< 10^{-4}$ |
| c | $\geq 10^{-6}$ to $< 3 \times 10^{-6}$ |
| d | $\geq 10^{-7}$ to $< 10^{-6}$ |
| e | $\geq 10^{-8}$ to $< 10^{-10}$ |

The calculated PL must be greater or equal to the necessary value, which arises from the calculation of the risk correlated to one single function and to the need to reduce it to an acceptable level.

| | | | |
|--------------------------------|---|---|------------------------------|
| S1 Slight danger | F1 Occasional danger and brief exposure | P1 - possibly avoidable danger P2 - largely unavoidable danger | PL= a PL= b |
| | F2 Frequent danger and long exposure | P1 - possibly avoidable danger P2 - largely unavoidable danger | |
| S2 Serious danger | F1 Occasional danger and brief exposure | P1 - possibly avoidable danger P2 - largely unavoidable danger | PL= c PL= d |
| | F2 Frequent danger and long exposure | P1 - possibly avoidable danger P2 - largely unavoidable danger | |

▶ **Manifold unit**



- ▶ Modular system
- ▶ Compact and linear design
- ▶ Maximum flexibility and reliability
- ▶ Up to 10 items assembly with unlimited configuration
- ▶ Flange coupling plug-n-play configuration
- ▶ Maintenance possible without completely disassembling the group
- ▶ Manifold integrated safety function elements
- ▶ Material and version wide selection
- ▶ Available in 4 sizes with connections from 1/8" to 1"
- ▶ Atex certification (II 2GD or II 3GD)

2
AIR TREATMENT

| Operational characteristics | | Size | Size 1 | Size 2 | Size 3 | Size 4 |
|--|-----------------|--|---|---|-----------------|---------------|
| Maximum working pressure * | | 10 bar / 13 bar / 16 bar / 20 bar | | | | |
| Minimum working pressure * | | 0,5 bar / 2,5 bar | | | | |
| Working temperature * | | -5°C +50°C / -30°C +80°C / -40°C +80°C | | | | |
| IN / OUT connections | T version | G1/4" | | G3/8" | | not available |
| | N version | G1/8" - G1/4" - 1/4" NPT | | G3/8" - G1/4" - 3/8" NPT | | |
| | P and L version | not available | | G3/8" - 1/4" NPT | | G1" - 1" NPT |
| Assembly configuration | | Stand alone Panel mounted thru fixing elements | | | | |
| Assembly positions | | Vertical ±5° with no restriction in case of elements without bowl | | | | |
| Max. fittings torque IN / OUT connections | | G1/8" metal: 15Nm G1/4" metal: 20Nm G1/4" technopolymer: 9Nm | G1/4" metal: 20Nm G3/8" metal: 25Nm G3/8" technopolymer: 16Nm | G3/8" metal: 25Nm G1/2" metal: 30Nm G1/2" technopolymer: 22Nm | G1" metal: 35Nm | |
| Max. fittings torque G1/8" pressure gauge connection | | G1/8" metal: 15Nm G1/8" technopolymer: 4Nm | | | | |



* Module configuration shall be identified according to individual technical details of each items included in applicable manifold

Manifold assembly

The assembly operation of selected items (module) is carried out thru dedicated quick connection flanges.
Both aluminum and techno polymer materials selection available, with fixing holes in case of panel mounting configuration.
Due to its design, Pneumax connection flanges allow user-friendly maintenance activities with no need of entire manifold disassembling procedure.



Thanks to a wide range of modules with different functions and characteristics, together with a wide choice of materials selection, make the Pneumax AIRPLUS air treatment units a robust, reliable and extremely flexible modular system, adaptable to different applications. AIRPLUS units properly assembled are modular with unlimited configurations and solutions and capable to satisfy and fulfill all their functions of compressed air treatment. Pneumax Airplus air treatment units can be integrated with safety elements that comply with EN-ISO 13849-1 and CE marking according to EU Machinery Directive, Annex V. Simple instruction provides an easy manifold configuration.



Configuration instructions

Manifold configuration as per following instructions.
As a result, a dedicated code will be provided, and the two main parameters will be identified, as follow:
Features applicable to all items included in manifold (i.e. version, size, connection, flow direction)
Assembly sequence of the single item + coupling flanges
Note: Max 10 items for each manifold.

The group can be configured by consulting the Pneumax catalog here:
<http://pneumax.partcommunity.com/3d-cad-models/>
also reachable through a special link available on the home page of the Pneumax website



Order codes

Initial code that identifies the main characteristics of the group such as:
- version
- size and connections
- flow direction
These will be the same for all the modules included in manifold, in accordance with the characteristics of the individual items available

Code that identifies the succession of individual modules and related coupling flanges included in manifold from module 1 to 10



| Version | |
|----------|---|
| N | Technopolymer body and metal inserts (not available for size 4) |
| T | Technopolymer body and thread (not available for size 4) |
| P | Aluminum body (not available for size 1) |
| L | Aluminum body, low temperature (not available for size 1) |

| Size and connections | |
|----------------------|---|
| 1A | Size 1 - G1/8" only for N version |
| 1B | Size 1 - G1/4" only for T - N versions |
| 1C | Size 1 - 1/4" NPT only for N version |
| 2A | Size 2 - G1/4" only for N version |
| 2B | Size 2 - G3/8" for all versions |
| 2C | Size 2 - 3/8" NPT only for N version - 1/4" NPT only for P - L versions |
| 3A | Size 3 - G3/8" only for N version |
| 3B | Size 3 - G1/2" for all versions |
| 3C | Size 3 - 1/2" NPT only for N - P - L versions |
| 4B | Size 4 - G1" only for P - L versions |
| 4C | Size 4 - 1" NPT only for P - L versions |

| Flow direction | |
|----------------|----------------------|
| | : From left to right |
| W | : From right to left |

| Module 1 | |
|----------|---------------------|
| | See list of modules |

| Mounting hardware 1 | |
|---------------------|------------------------|
| X | Technopolymer flange X |
| Y | Technopolymer flange Y |
| K | Aluminium flange X |
| T | Aluminium flange Y |

| Module 2 | |
|----------|---------------------|
| | See list of modules |

| Mounting hardware 1 | |
|---------------------|------------------------|
| X | Technopolymer flange X |
| Y | Technopolymer flange Y |
| K | Aluminium flange X |
| T | Aluminium flange Y |

| Module 10 | |
|-----------|---------------------|
| | See list of modules |





List of modules

Below the list of modules available for assembly of the manifold

| | | | | | | | | | |
|---|-----------|--|--|--|---|--|--|--|--|
| FILTER | F | A : 5 µm B : 20 µm C : 50 µm | : Semi-automatic drain S : Automatic drain | : Technopolymer protection - PC bowl N : Technopolymer protection - PA bowl P : Metal protection - PC bowl R : Metal protection - PA bowl T : Metal bowl | | | | | |
| COALESCING FILTER | DA | | : Semi-automatic drain S : Automatic drain | : Technopolymer protection - PC bowl N : Technopolymer protection - PA bowl P : Metal protection - PC bowl R : Metal protection - PA bowl T : Metal bowl | | | | | |
| OIL REMOVAL FILTER | D | AV : Size 4 BV : Size 3 CV : Size 3 oversize cartridge | : Semi-automatic drain S : Automatic drain | : Technopolymer protection - PC bowl N : Technopolymer protection - PA bowl P : Metal protection - PC bowl R : Metal protection - PA bowl T : Metal bowl | | | | | |
| CARBON FILTER | DD | | | : Technopolymer protection - PC bowl N : Technopolymer protection - PA bowl P : Metal protection - PC bowl R : Metal protection - PA bowl T : Metal bowl | | | | | |
| REGULATOR | R | : G1/8" connection M : Integrated pressure gauge W : Integrated pressure gauge Right - Left P : Digital pressure switch Z : Digital pressure switch Right - Left | A : 0-2 bar B : 0-4 bar C : 0-8 bar D : 0-12 bar | : With relieving and improved relieving L : Without relieving R : Improved relieving | : Standard knob K : Lockable knob | A : Cable 150mm M8 PNP B : Cable 150mm M8 NPN C : Cable 2m PNP D : Cable 2m NPN | | | |
| FILTER REGULATOR | E | : G1/8" connection M : Integrated pressure gauge W : Integrated pressure gauge Right - Left P : Digital pressure switch Z : Digital pressure switch Right - Left | A : 5 µm B : 20 µm C : 50 µm | A : 0-2 bar B : 0-4 bar C : 0-8 bar D : 0-12 bar | : Semi-automatic drain S : Automatic drain | : With relieving L : Without relieving | : Standard knob K : Lockable knob | A : Cable 150mm M8 PNP B : Cable 150mm M8 NPN C : Cable 2m PNP D : Cable 2m NPN | : Technopolymer protection - PC bowl N : Technopolymer protection - PA bowl P : Metal protection - PC bowl R : Metal protection - PA bowl T : Metal bowl |
| LUBRICATOR | L | | : No electric level sensor device A : Electrical minimum level sensor NO C : Electrical minimum level sensor NC | | | | | : Technopolymer protection - PC bowl N : Technopolymer protection - PA bowl P : Metal protection - PC bowl R : Metal protection - PA bowl | |
| SHUT OFF VALVE | V | L : Manual P : Pneumatic E : Solenoid | | 15mm coil A4 : 12 V DC A5 : 24 V DC A6 : 24 V AC (50-60 Hz) A7 : 110 V AC (50-60 Hz) A8 : 230 V AC (50-60 Hz) A9 : 24 V DC (1 Watt) 22mm coil B2 : Mechanical M2, without coil B4 : 12 V DC B5 : 24 V DC B6 : 24 V AC (50-60 Hz) B7 : 110 V AC (50-60 Hz) B8 : 230 V AC (50-60 Hz) B9 : 24 V DC (2 Watt) 30mm coil C5 : 24 V DC C6 : 24 V AC (50-60 Hz) C7 : 110 V AC (50-60 Hz) C8 : 230 V AC (50-60 Hz) C9 : 24 V DC (2 Watt) | | | | | |
| SAFETY VALVE | V | S : Single 2S : Double | | : Without connection M : Integrated pressure gauge W : Integrated pressure gauge (Right - Left) G : G1/8" pressure gauge connection | | | X = Flange X Y = Flange Y K = Aluminium flange Y Z = Aluminium flange X | | |
| PROGRESSIVE START-UP VALVE | AP | : Size 1 - Size 2 - Size 3 W : Size 4 - flow direction Right - Left | | | | | | | |
| AIR INTAKE | PA | | | | | | | | |
| AIR INTAKE WITH PRESSURE GAUGE OR DIGITAL PRESSURE SWITCH INTEGRATED | P | | M : Integrated pressure gauge W : Integrated pressure gauge (Right - Left) P : Integrated digital pressure switch Z : Integrated digital pressure switch (Right - Left) | | | | A : Cable 150mm M8 PNP B : Cable 150mm M8 NPN C : Cable 2m PNP D : Cable 2m NPN | | |
| PRESSURE SWITCH | PP | : Size 1 - Size 2 - Size 3 W : TG4 - flow direction Right - Left | | | | | | | |

Examples of module identification: 5µm filter, automatic drain, metal bowl is identified as: **F A S T**

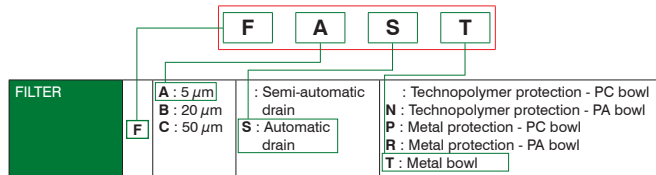

- Filter regulator with pressure gauge 50µm, 0-12 bar semi-automatic drain, without relieving, technopolymer bowl protection, PA bowl, is identified as: **E M C D L N**

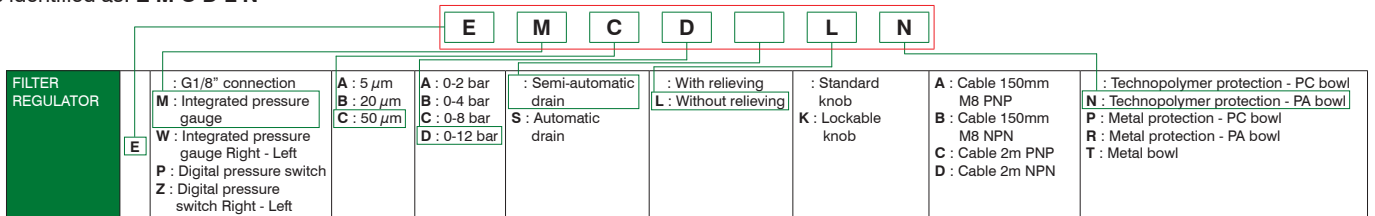

AIRPLUS assembled groups configuration

Configuration sample:

- Shut off valve
- Filter regulator, 20µm, 0-12bar, automatic drain
- Lubricator with electrical minimum level sensor NO
- Electric shut off valve, 22mm, without coil
- Progressive start-up valve

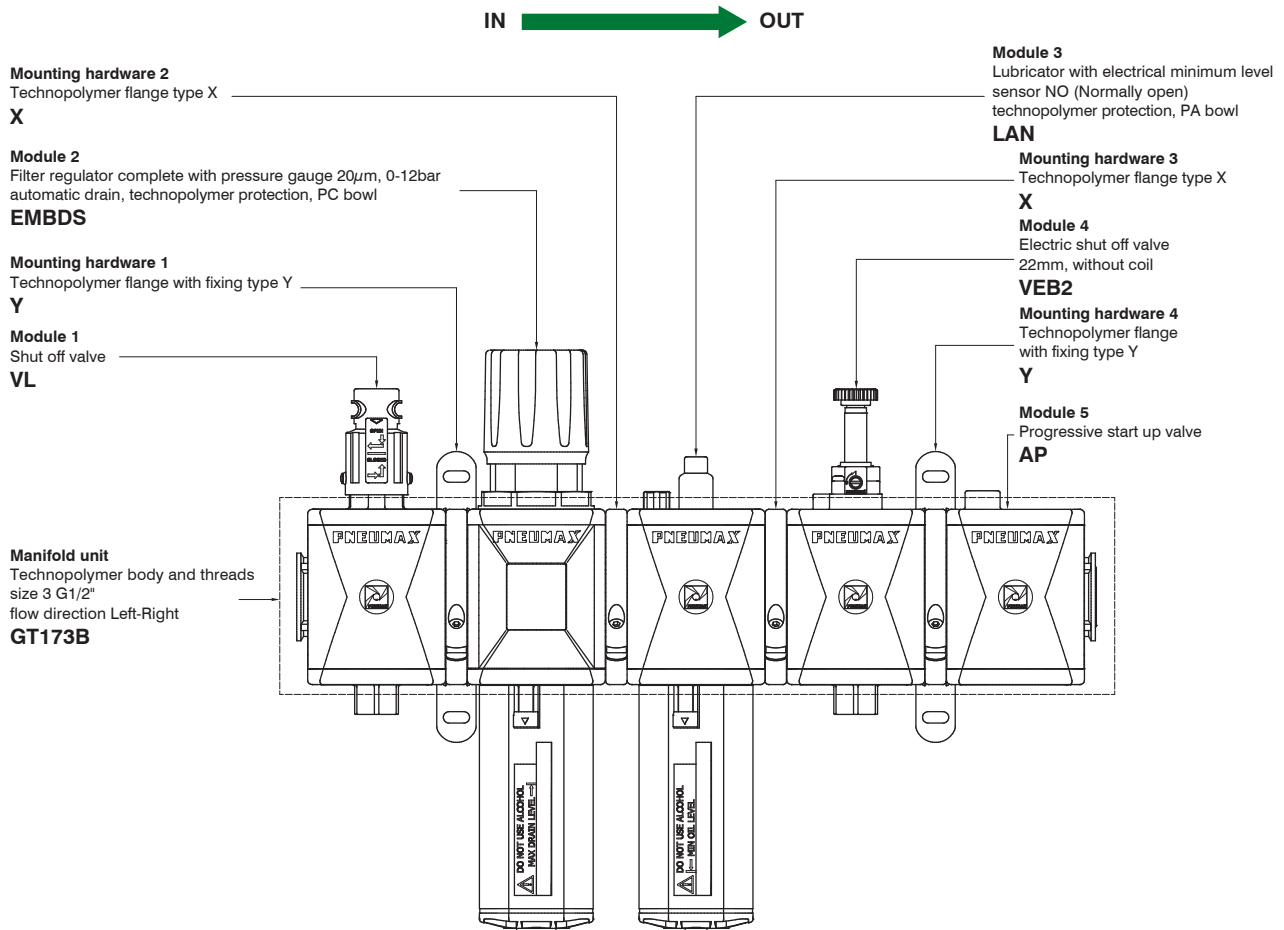

2 AIR TREATMENT

Applicable order code:

Initial code that identifies the main characteristics of the group such as:
- version
- size and connections
- flow direction
These will be the same for all the modules included in manifold, in accordance with the characteristics of the individual items available

Code that identifies the succession of individual modules and related coupling flanges included in manifold from module 1 to 10

| | | | | | | | | | | | | | | | | | | | | | | |
|---|---|----|----|--|---|----|---|---|---|-------|---|---|---|-----|---|---|---|------|---|---|---|----|
| G | T | 17 | 3B | | - | VL | - | Y | - | EMBDS | - | X | - | LAN | - | X | - | VEB2 | - | Y | - | AP |
|---|---|----|----|--|---|----|---|---|---|-------|---|---|---|-----|---|---|---|------|---|---|---|----|



GT173 - VL - Y - EMBDS - X - LAN - X - VEB2 - Y - AP

Flanges positioning schematic

Here below some indications related to flanges positioning according to the number of seats. Pneumax recommend configuration in compliance with the following schematic:

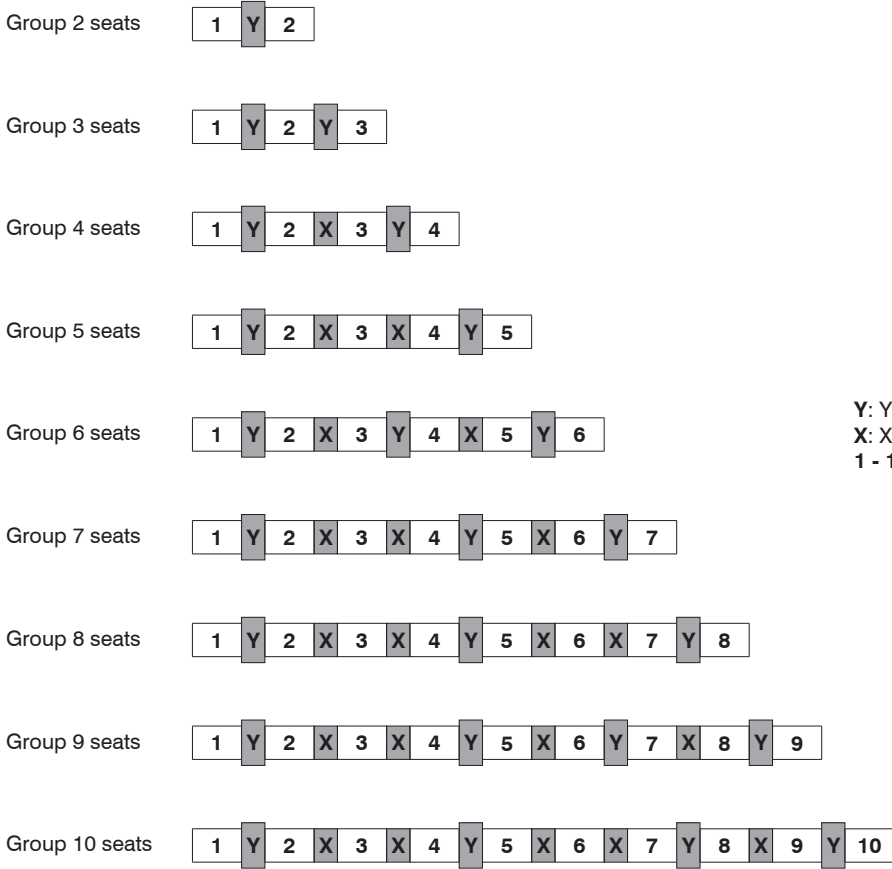

Y: Y type flange (Aluminium or technopolymer)
X: X type flange (Aluminium or technopolymer)
1 - 10 : AIRPLUS modules

2
AIR TREATMENT

Quick coupling flanges

Pneumax Airplus quick coupling flanges series allow both module rapid fixing and panel mounted configuration. Due to its design, Pneumax connection flanges allow user-friendly maintenance activities with no need of entire manifold disassembling procedure. Two types of flange are available: X type flange for assembling the modules together, and Y type flange suitable for panel mounted also. Both types are made of technopolymer or die-cast aluminum.

► **Technopolymer flanges**

Flange Y

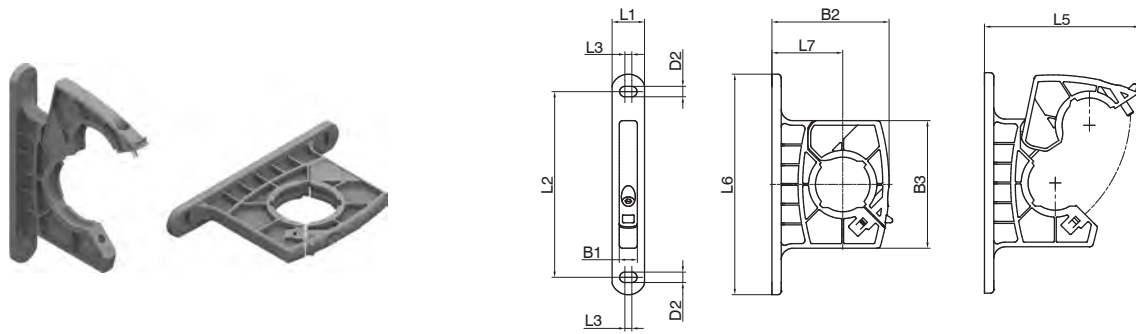

Flange X

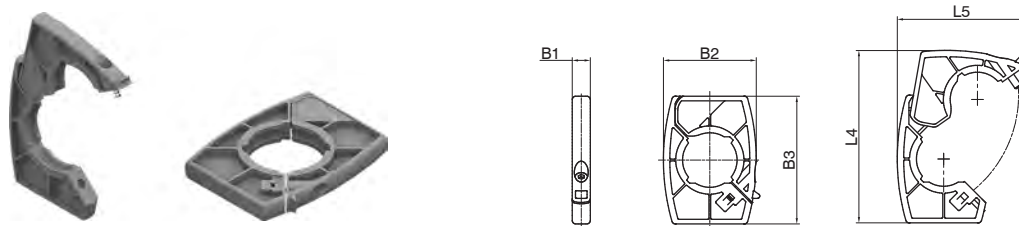

| Model | B1 | B2 | B3 | D2 | L1 | L2 | L3 | L4 | L5 | L6 | L7 |
|-------|------|-------|-----|------|----|-----|-----|-------|-------|-------|------|
| T171Y | 7,8 | 50,5 | 55 | Ø4,5 | 14 | 80 | 3 | / | 66 | 95 | 30,5 |
| T171X | | 40 | | / | / | / | / | 74,5 | 55,5 | / | / |
| T172Y | 9,7 | 67,6 | 68 | Ø5,2 | 18 | 95 | 6,8 | / | 86,5 | 117,9 | 40,5 |
| T172X | | 53,6 | | / | / | / | / | 96,5 | 72,5 | / | / |
| T173Y | 9,7 | 75,5 | 80 | Ø5,2 | 18 | 110 | 6,8 | / | 98,3 | 133 | 44,5 |
| T173X | | 62 | | / | / | / | / | 112,8 | 85 | / | / |
| T174Y | 13,7 | 106,5 | 105 | Ø8,5 | 25 | 148 | 6,5 | / | 133,5 | 175 | 64 |
| T174X | | 85 | | / | / | / | / | 153,5 | 112 | / | / |

► **Aluminium flanges**

Flange Y

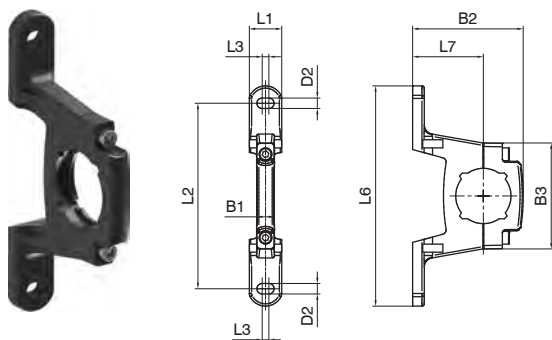

Flange X

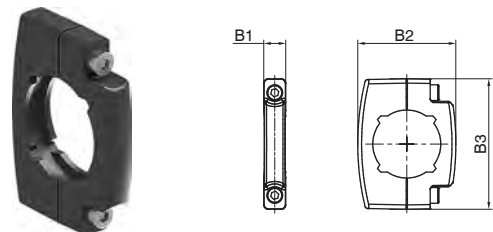

| Model | B1 | B2 | B3 | D2 | L1 | L2 | L3 | L4 | L5 | L6 | L7 |
|-------|------|-------|------|------|----|-----|-----|-------|-------|-------|------|
| N171Y | 7,8 | 47,7 | 45,7 | Ø4,5 | 14 | 80 | 3 | / | 66 | 95 | 30,5 |
| N171X | | 34,4 | | / | / | / | / | 74,5 | 55,5 | / | / |
| N172Y | 9,7 | 64,6 | 55,6 | Ø5,2 | 18 | 95 | 6,8 | / | 86,5 | 117,9 | 40,5 |
| N172X | | 55,6 | | / | / | / | / | 96,5 | 72,5 | / | / |
| N173Y | 9,7 | 75,5 | 56 | Ø5,2 | 18 | 110 | 6,8 | / | 98,3 | 133 | 44,5 |
| N173X | | 62 | | / | / | / | / | 112,8 | 85 | / | / |
| N174Y | 13,7 | 106,5 | 102 | Ø8,5 | 25 | 148 | 6,5 | / | 133,5 | 175 | 64 |
| N174X | | 85 | | / | / | / | / | 153,5 | 112 | / | / |



Product overview

2
AIR TREATMENT

| PRODUCT | BODY MATERIAL | SIZES AND CONNECTIONS | | | |
|--|---------------|-----------------------|---------------|------------------------|--------|
| | | SIZE 1 | SIZE 2 | SIZE 3 | SIZE 4 |
| FILTER | Zinc alloy | G1/8" - G1/4" | / | / | / |
| | Technopolymer | G1/8" - G1/4" | / | / | / |
| | Aluminum | / | G1/4" - G3/8" | G3/8" - G1/2" - G 3/4" | G1" |
| DYNAMIC DRIER | Aluminum | / | / | / | G1" |
| FILTER REGULATORS | Zinc alloy | G1/8" - G1/4" | / | / | / |
| | Technopolymer | G1/8" - G1/4" | / | / | / |
| | Aluminum | / | G1/4" - G3/8" | G3/8" - G1/2" - G 3/4" | / |
| REGULATORS | Zinc alloy | G1/8" - G1/4" | / | / | / |
| | Technopolymer | G1/8" - G1/4" | / | / | / |
| | Aluminum | / | G1/4" - G3/8" | G3/8" - G1/2" - G 3/4" | G1" |
| REGULATORS WITH INTEGRATED PRESSURE GAUGE | Zinc alloy | G1/8" - G1/4" | / | / | / |
| | Technopolymer | G1/8" - G1/4" | / | / | / |
| | Aluminum | / | G1/4" - G3/8" | G3/8" - G1/2" | / |
| HIGH SENSITIVE AIR PRESSURE REGULATORS WITH HIGH FLOW RATE RELIEVING | Aluminum | G1/4" | / | G1/2" | / |
| HIGH SENSITIVE PRESSURE REGULATOR WITH PNEUMATIC PILOT | Aluminum | / | / | G1/2" | / |
| PILOTED PRESSURE REGULATORS | Aluminum | / | G1/4" - G3/8" | G3/8" - G1/2" | G1" |
| PANEL MOUNTING PRESSURE REGULATOR | Technopolymer | G1/8" - G1/4" | / | / | / |
| PRESSURE REGULATORS FOR MANIFOLD | Zinc alloy | G1/8" - G1/4" | / | / | / |
| MANIFOLD PRESSURE REGULATORS | Zinc alloy | G1/8" - G1/4" | / | / | / |
| LUBRICATORS | Zinc alloy | G1/8" - G1/4" | / | / | / |
| | Technopolymer | G1/8" - G1/4" | / | / | / |
| | Aluminum | / | G1/4" - G3/8" | G3/8" - G1/2" - G 3/4" | G1" |
| SHUT-OFF VALVE | Zinc alloy | G1/4" | / | / | / |
| | Technopolymer | G1/4" | / | / | / |
| | Aluminum | / | G3/8" | G1/2" | G1" |
| ELECTRIC SHUT-OFF VALVE | Zinc alloy | G1/4" | / | / | / |
| | Technopolymer | G1/4" | / | / | / |
| | Aluminum | / | G3/8" | G1/2" | / |
| PNEUMATIC SHUT-OFF VALVE | Zinc alloy | G1/4" | / | / | / |
| | Technopolymer | G1/4" | / | / | / |
| | Aluminum | / | G3/8" | G1/2" | / |
| PROGRESSIVE START-UP VALVE | Aluminum | G1/4" | G3/8" | G1/2" | G1" |
| AIR INTAKE | Aluminum | G1/4" | G3/8" | G1/2" | G1" |
| AIR INTAKE -"H" PROFILE | Aluminum | G1/4" | G3/8" | G1/2" | / |
| PRESSURE SWITCH COMPLETE WITH ADAPTER | Aluminum | G1/8" | G3/8" | G1/2" | Ø36 |